

Albany County Request for Contract Approval

Contract #	2022-329
Contract Type	B) CAB Contract
Contract Action	A) New
Contract Action Type	A) New
Department	A3110 - Sheriff
Date Submitted	Wednesday, May 04, 2022
Contact Person	Remmert, Thomas
Contact Phone	() -518
Vendor Info	B & H PHOTO 420 NINTH AVE., NEW YORK, NY 10001
Estimated Amount	\$20,836.00
Estimated Term	5/1/2022 to 12/31/2022
Scope of Services	FOR PURCHASE OF AUDIO VIDEO EQUIPMENT OVER \$20,000 USING GRANT FUNDS
Budget Line Item	AA3110 - 22750.EMP20 - - -
Fiscal Impact	County: 100.00% State: 0.00% Federal: 0.00% Local: 0.00% Other: 0.00%
BID, RFP, RFQ Completed?	N/A

Budget Analyst

Date

For Contract Board Use:

Date Approved

Daniel P. McCoy
Albany County Executive

Bruce A. Hidley
Albany County Clerk

Andrew Joyce, Chairman
Albany County Legislature



Government, Education, and Corporate Department

For Pricing Requests, Purchase Orders, and Customer Service:

Phone: 800-947-8003
212-239-7503

Fax: 800-858-5517
212-239-7759

Email: Education: emailbids@bhphoto.com Fed Gov: federalsales@bhphoto.com
Corporate: corporatesales@bhphoto.com State and Local: biddept@bhphoto.com

The Professional's Source

420 Ninth Avenue, New York City, NY 10001 • www.bhphotovideo.com

Federal ID#: 15-2768071

Prices Are Valid Until: 05/27/22

Quote No.: 1082551025

Reference No.: R201202-OMNIA

Sold To:

Albany County Sheriff
16 Eagle St Court House Rm 79
Attn: Hon Craig D Apple
ALBANY, NY 12207

Ship To:

Albany County Sheriff'S Office
58 Verda Ave
Attn: Sheriff'S Office Emergency
CLARKSVILLE, NY 12041

Bill Phone: (518)447-7140
Work Phone: (518)487-5407

(518)720-8025

Date	Customer Code	Terms	Salesperson	Ship Via
04/25/22	61303098	N/A	WB	MULTIPLE
Qty Ord	Item Description	SKU# MFR#	Item Price	Amount
13	SAMSUNG 60" TU 7000 LED 4K UHD 7SERS SMART TV/REG	SAUN60TU7000 (UN60TU7KFXZA)	513.00	6,669.00
6	AMAZON ECHO SHOW 8/2G/13 MP CAM/8-HD TS/G.WHT/REG	AMB084DC4LW6 (B084DC4LW6)	128.00	768.00
5	SAMSUNG HW-S60A SPEAKER/REG	SAHWS60A (HWS60AZA)	262.00	1,310.00
	Price After \$50.00 Instant Savings Exp. 05/01/22			
	This item currently has a price of \$277.99 while supplies last.			
4	UBIQUITI UNIFI AC AP 4X4 MU MIMO WAVE2 5-PK/REG	UBUAPNANOHD5 (UAPNANOHD5US)	739.00	2,956.00
	This item currently has a price of \$779.99 while supplies last.			
4	SAMSUNG 55" LED 4K UHD 7 SERIES TV/REG	SAUN55TU7000 (UN55TU7000FX)	394.00	1,576.00
2	HOVERCAM PILOT X WL DIGITAL PODIUM/15 PROCESSOR/REG <i>This Is A Special Order Item, And Is Not Returnable.</i>	HOHCPX15 (HCPX15)	3,140.00	6,280.00

Continued on Next Page ...



Government, Education, and Corporate Department

For Pricing Requests, Purchase Orders, and Customer Service:

Phone: 800-947-8003
212-239-7503

Fax: 800-858-5517
212-239-7759

Email: Education: emailbids@bhphoto.com Fed Gov: federsales@bhphoto.com
Corporate: corporatesales@bhphoto.com State and Local: biddept@bhphoto.com

The Professional's Source

420 Ninth Avenue, New York City, NY 10001 • www.bhphotovideo.com

Federal ID#: 13-2788071

Quote No.: 1082551025

Date	Customer Code	Terms	Salesperson	Ship Via
	61303098	N/A	Sism	MULTIPLE

Qty Ord	Item Description	SKU# MFR#	Item Price	Amount
<p>PLEASE NOTE: -----</p> <p>**** Please reference your quote number on all PO's ****</p> <p>**** ALL PRICES ARE LISTED IN USD ****</p> <p>Certain items may be enforced by vendor to sell at the vendor-imposed price posted at the time of order.</p>				

Payment Type - N/A	- Amount'	Sub-Total:	19,559.00
		Shipping:	1,276.55
		Total:	20,835.55

BNEI_quote



February 23, 2021

Israel Mamann
Manager – B2B Contracts
B&H Foto and Electronics DBA B&H
420 Ninth Ave.
New York, NY 10001
israelm@bhphoto.com

Re: Award of Contract #R201202

Dear Mr. Mamann:

Per official action taken by the Board of Directors of Region 4 Education Service Center on February 23, 2021, we are pleased to announce that after successful negotiated terms and conditions, B&H Foto and Electronics DBA B&H has been awarded an annual contract for the following, based on the sealed proposal (RFP#20-12) submitted on December 15, 2020:

Commodity/Service

Supplier

Audio Visual Equipment, Accessories
& Services

B&H Foto and Electronics DBA B&H

This contract is effective April 1, 2021 and will expire on March 31, 2024. As indicated above, your contract # is R201202. This contract may be renewed annually for an additional two (2) years if mutually agreed upon by Region 4 ESC/OMNIA Partners, Public Sector and B&H Foto and Electronics DBA B&H.

Your participation in the proposal process is appreciated and we look forward to a successful partnership. Please feel free to provide copies of this letter to your sales representative(s) to assist in their daily course of business.

If you have any questions, please contact Deborah Bushnell, the Contract Manager assigned to your contract, at 713-554-7348 or deborah.bushnell@omniapartners.com.

Sincerely,

DocuSigned by:
Robert Zingelmann
30EE15BF EF1C4C6...

Robert Zingelmann
Chief Financial Officer, Finance and Operations Services

3/23/22

VENDOR B & H PHOTO

QUANTITY

4	SAMSUNG TU7000 55" B&H# SAUN55TU7000 AT \$ 427.99	1,711.96
13	SAMSUNG TU7000 60" B&H SAUN60TU7000 AT \$ 547.99 EA	7,123.87
54	SAMSUNG TU7000 43" B&H SAUN43TU7001 AT \$ 339.00 EA	18,306.00
4	UBIQUITI NETWORKS UNIFI NANO HD 4X4 MU-MIMO 802.11AC WAVE-2 ACCESS POINT (5-PACK) B&H UBUAPNANOHD5 AT 779.99 EA	3,119.96
2	UBIQUITI NETWORKS UNIFI AC MESH WIDE AREA OUTDOOR DUAL-BAND ACCESS POINT (5-PACK) B&H # UBUAPACM5 AT \$ 444.00 EA	888.00
2	UBIQUITI NETWORKS UNIFI DREAM MACHINE PRO B&H # UBUDMPRO @ \$ 379.00 EA	758.00
3	UNIQUITI NETWORKS UNIFI MANAGED POE+ 16-PORT GIGABIT SWITCH WITH SFP (150W) B&H # UBUS16150W AT \$ 299.00 EA	897.00
4	APPLE TV 4K (64GB, 2021) B7H APTV4K642021 AT \$ 199.00 EA	796.00
2	SAMSUNG HW-S60A VIRTUAL 5-CHANNEL SOUNDBAR B&H SAHWS60A AT \$ 327.99EA	1,639.95
6	AMAZON ECHO SHOW 8 B&H # AMB084DC4LW6 AT \$ 102.99	617.94
2	HOVER CAMERA PILOT PLUS 5 WIRELESS DIGITAL PODIUM (17 PROCESSOR) B&H # HOHCP517 \$ 7141.07 EA	14,282.14

GENERAL LEDGER SUMMARY 50,140.82

3110.22750.EMP20

50,140.82 ENCUMBRANCE 22044006

DELIVER TO: ALBANY COUNTY SHERIFF'S OFFICE
ATTN: THOMAS REMMERT
58 VERDA AVENUE
CLARKSVILLE NY 12041

AUTHORIZED BY: 

DATE: 3/24/22

Albany County Request for Contract Approval

Contract #	2022-261
Contract Type	B) CAB Contract
Contract Action	A) New
Contract Action Type	A) New
Department	A3020 - Emergency 911
Date Submitted	Monday, April 11, 2022
Contact Person	Demarest, Kevin
Contact Phone	() -518
Vendor Info	Drb Business Interiors 153 Regent St , Saratoga, NY 12866.
Estimated Amount	\$58,341.70
Estimated Term	4/11/2022 to 4/11/2023
Scope of Services	To provide furniture for the new E-911 building on 58 Verda
Budget Line Item	AA3020 - 2 - - -
Fiscal Impact	County: 100.00% State: 0.00% Federal: 0.00% Local: 0.00% Other: 0.00%
BID, RFP, RFQ Completed?	N/A

Budget Analyst

Date

For Contract Board Use:

Date Approved

Daniel P. McCoy
Albany County Executive

Bruce A. Hidley
Albany County Clerk

Andrew Joyce, Chairman
Albany County Legislature



BUSINESS INTERIORS

153 REGENT STREET

SARATOGA SPRINGS, NEW YORK 12866

518.306.5233

ALBANY COUNTY SHERIFF-CLARKSVILLE-FURNITURE BUDGET

Item	Qty.	MFG.	Model #		Unit	Price Extended
1	2	HON	HML1S	Grove Single Seat Lounge	\$740.39	\$1,480.78
	102		.B	Arm: Tapered		
			\$(2)	Grade 2 Upholstery		
			~	Undecided FABRIC Option		
			.TS	Tapered Square Leg		
			~	Undecided COLOR Option		
2	1	HON	HCESS24LM	Laminate End Table Soft Square 24Wx24Lx22H	\$479.14	\$479.14
	102		\$(L1STD)	Grd L1 Standard Laminates		
			~	Undecided LAMINATE Option		
			~	Undecided WOOD Option		
			\$(P1)	P1 Paint Opts		
			~	Undecided PAINT Option		
3	4	HON	H105892	10500 Series 60Wx30Dx29-1/2H Dbl Ped Dsk 3/2 Rect Top	\$617.38	\$2,469.52
	103 105 106 107		\$(L1STD)	Grd L1 Standard Laminates		
			~	Undecided LAMINATE Option		
4	4	HON	H1522	Wood Center Drawer 22W x 15-3/8D	\$77.71	\$310.84
	103 105 106 107		\$(L1STD)	Grd L1 Standard Laminates		
			~	Undecided LAMINATE Option		
5	4	HON	HIGS6	Ignition Guest/Multi-Purpose Chair Four-Leg Stacking	\$207.75	\$831.00
	103 105 106 107		.F	Arm: Fixed		
			.H	Hard		
			.U	Back: Upholstered		



BUSINESS INTERIORS

153 REGENT STREET

SARATOGA SPRINGS, NEW YORK 12866

518.306.5233

ALBANY COUNTY SHERIFF-CLARKSVILLE-FURNITURE BUDGET

Item	Qty.	MFG.	Model #		Unit	Price Extended
			\$(2)	GRADE: II UPHOLSTERY		
			~	Undecided FABRIC Option		
			~	Undecided FRAME Option		
6	1	HON	H10534	10500 Series Stack-on Storage 72"W x 14-5/8D x 37-1/8H	\$418.62	\$418.62
	108		\$(L1STD)	Grd L1 Standard Laminates		
			~	Undecided LAMINATE Option		
7	1	HON	H10548L	10500 Series Cred Lateral File Left 72W 24D	\$579.50	\$579.50
	108		\$(L1STD)	Grd L1 Standard Laminates		
			~	Undecided LAMINATE Option		
8	1	HON	H10560	10500 Series Bridge 42W x 24D x 29-1/2H	\$144.88	\$144.88
	108		\$(L1STD)	Grd L1 Standard Laminates		
			~	Undecided LAMINATE Option		
9	1	HON	H105856	10500 Series Back enclosure for 72"W Stack on Storage	\$98.41	\$98.41
	108		\$(L1STD)	Grd L1 Standard Laminates		
			~	Undecided LAMINATE Option		
10	1	HON	H105895R	10500 Series 72Wx36Dx29-1/2H Sgl edDskRH B/B/F RectTop	\$563.49	\$563.49
	108		\$(L1STD)	Grd L1 Standard Laminates		
			~	Undecided LAMINATE Option		
11	1	HON	H1522	Wood Center Drawer 22W x 15-3/8D	\$77.71	\$77.71
	108		\$(L1STD)	Grd L1 Standard Laminates		
			~	Undecided LAMINATE Option		



BUSINESS INTERIORS

153 REGENT STREET

SARATOGA SPRINGS, NEW YORK 12866

518.306.5233

ALBANY COUNTY SHERIFF-CLARKSVILLE-FURNITURE BUDGET

Item	Qty.	MFG.	Model #		Unit	Price Extended
12	1	HON	H90056	10500 Series Tckbd for 72"W Stack on Strg Bck Enclosure	\$124.96	\$124.96
	108		\$(B)	Gr B Fab		
			~	Undecided FABRIC Option		
13	1	HON	HH870942	Tasklight 42W	\$104.26	\$104.26
	108					
14	1	HON	H9190A	Flagship 42W 2-Drw "A" Pull Lateral 42W 28H 18D	\$528.33	\$528.33
	108					
			.L	Standard Random Key Lock		
			\$(P1)	P1 Paint Opts		
			~	Undecided PAINT Option		
15	1	HON	H919492	Double Rail Hanging File Racks(2 Pack)	\$27.79	\$27.79
	108					
16	2	HON	HIGS6	Ignition Guest/Multi-Purpose Chair Four-Leg Stacking	\$207.75	\$415.50
	108					
			.F	Arm: Fixed		
			.H	Hard		
			.U	Back: Upholstered		
			\$(2)	GRADE: II UPHOLSTERY		
			~	Undecided FABRIC Option		
			~	Undecided FRAME Option		
17	1	HON	H10534	10500 Series Stack-on Storage 72"W x 14-5/8D x 37-1/8H	\$418.62	\$418.62
	109					
			\$(L1STD)	Grd L1 Standard Laminates		
			~	Undecided LAMINATE Option		
18	1	HON	H10547R	10500 Series Cred Lateral File Right 72W 24D	\$579.50	\$579.50
	109					



BUSINESS INTERIORS

153 REGENT STREET

SARATOGA SPRINGS, NEW YORK 12866

518.306.5233

ALBANY COUNTY SHERIFF-CLARKSVILLE-FURNITURE BUDGET

Item	Qty.	MFG.	Model #		Unit	Price Extended
			\$(L1STD)	Grd L1 Standard Laminates		
			~	Undecided LAMINATE Option		
19	1	HON	H105535	10500 Series Bookcase 5-shelf 36Wx13-1/8Dx71H	\$341.69	\$341.69
	109		\$(L1STD)	Grd L1 Standard Laminates		
			~	Undecided LAMINATE Option		
20	1	HON	H10570	10500 Series Bridge 47W x 24D x 29-1/2H	\$150.73	\$150.73
	109		\$(L1STD)	Grd L1 Standard Laminates		
			~	Undecided LAMINATE Option		
21	1	HON	H105856	10500 Series Back enclosure for 72"W Stack on Storage	\$98.41	\$98.41
	109		\$(L1STD)	Grd L1 Standard Laminates		
			~	Undecided LAMINATE Option		
22	1	HON	H105896L	10500 Series 72Wx36Dx29-1/2H SglPedDskLH B/B/F RectTop	\$563.49	\$563.49
	109		\$(L1STD)	Grd L1 Standard Laminates		
			~	Undecided LAMINATE Option		
23	1	HON	H1522	Wood Center Drawer 22W x 15-3/8D	\$77.71	\$77.71
	109		\$(L1STD)	Grd L1 Standard Laminates		
			~	Undecided LAMINATE Option		
24	1	HON	H90056	10500 Series Tckbd for 72"W Stack on Strg Bck Enclosure	\$124.96	\$124.96
	109		\$(B)	Gr B Fab		
			~	Undecided FABRIC Option		



BUSINESS INTERIORS

153 REGENT STREET

SARATOGA SPRINGS, NEW YORK 12866

518.306.5233

ALBANY COUNTY SHERIFF-CLARKSVILLE-FURNITURE BUDGET

Item	Qty.	MFG.	Model #		Unit	Price Extended
25	1	HON	HH870942	Tasklight 42W	\$104.26	\$104.26
	109					
26	2	HON	H9190A	Flagship 42W 2-Drw "A" Pull Lateral 42W 28H 18D	\$528.33	\$1,056.66
	109					
			.L	Standard Random Key Lock		
			\$(P1)	P1 Paint Opts		
			~	Undecided PAINT Option		
27	5	HON	H919492	Double Rail Hanging File Racks(2 Pack)	\$27.79	\$138.95
	109					
28	8	HON	HIGS6	Ignition Guest/Multi-Purpose Chair Four-Leg Stacking	\$207.75	\$1,662.00
	109					
			.F	Arm: Fixed		
			.H	Hard		
			.U	Back: Upholstered		
			\$(2)	GRADE: II UPHOLSTERY		
			~	Undecided FABRIC Option		
			~	Undecided FRAME Option		
29	1	HON	HTLA3672	Preside 72W x 36D Racetrack Shaped Laminate Top	\$258.90	\$258.90
	109					
			.G	2MM/Flat		
			~	Undecided EDGE Option		
			.N	No Grommets		
			\$(L1STD)	Grd L1 Standard Laminates		
			~	Undecided LAMINATE Option		
30	1	HON	HTLP72	Preside Laminate Panel Base For 72" W Table Tops	\$237.42	\$237.42
	109					
			\$(L1STD)	Grd L1 Standard Laminates		



BUSINESS INTERIORS

153 REGENT STREET

SARATOGA SPRINGS, NEW YORK 12866

518.306.5233

ALBANY COUNTY SHERIFF-CLARKSVILLE-FURNITURE BUDGET

Item	Qty.	MFG.	Model #		Unit	Price Extended
			~	Undecided LAMINATE Option		
31	2	HON	HTLS42	Preside 42" Square Shaped LaminateTop	\$198.76	\$397.52
	110		.G	2MM/Flat		
			~	Undecided EDGE Option		
			~	Undecided GROMMET Option		
			~	Undecided LAMINATE Option		
32	2	HON	HTXLEGS	Preside Standing Height Aluminum X-Leg	\$261.24	\$522.48
	110		\$(P1)	P1 Paint Opts		
			~	Undecided PAINT Option		
33	1	HON	H1522	Wood Center Drawer 22W x 15-3/8D	\$77.71	\$77.71
	120		\$(L1STD)	Grd L1 Standard Laminates		
			~	Undecided LAMINATE Option		
34	1	HON	H90056	10500 Series Tckbd for 72"W Stack on Strg Bck Enclosure	\$124.96	\$124.96
	120		\$(B)	Gr B Fab		
			~	Undecided FABRIC Option		
35	1	HON	HH870942	Tasklight 42W	\$104.26	\$104.26
	120					
36	1	HON	HNL1530BK5	30x14-1/4x65 Bookcase 5-shelf	\$359.26	\$359.26
	120		.G	Smooth, Flat		
			~	Undecided EDGE Option		
			\$(L1STD)	Grd L1 Standard Laminates		
			~	Undecided LAMINATE Option		



BUSINESS INTERIORS

153 REGENT STREET

SARATOGA SPRINGS, NEW YORK 12866

518.306.5233

ALBANY COUNTY SHERIFF-CLARKSVILLE-FURNITURE BUDGET

Item	Qty.	MFG.	Model #		Unit	Price Extended
			\$(L1STD)	Grd L1 Standard Laminates		
			~	Undecided LAMINATE2 Option		
37	1	HON	HNL2448BF	48x24x29-1/2 Bridge w/full mod	\$191.74	\$191.74
	120		.G	Smooth, Flat		
			~	Undecided EDGE Option		
			~	Undecided GROMMET Option		
			\$(L1STD)	Grd L1 Standard Laminates		
			~	Undecided LAMINATE Option		
			\$(L1STD)	Grd L1 Standard Laminates		
			~	Undecided LAMINATE2 Option		
38	1	HON	HNL2472RLC	72x24x29-1/2 Credenza w/Lateral Rt	\$676.74	\$676.74
	120		.G	Smooth, Flat		
			~	Undecided EDGE Option		
			~	Undecided PULL Option		
			~	Undecided GROMMET Option		
			\$(L1STD)	Grd L1 Standard Laminates		
			~	Undecided LAMINATE Option		
			\$(L1STD)	Grd L1 Standard Laminates		
			~	Undecided LAMINATE2 Option		
			\$(L1STD)	Grd L1 Standard Laminates		
			~	Undecided COLOR Option		
39	1	HON	HNL3672FD	72x15x35-1/4 Stack-on Storage frosted drs	\$813.80	\$813.80
	120		\$(L1STD)	Grd L1 Standard Laminates		



BUSINESS INTERIORS

153 REGENT STREET

SARATOGA SPRINGS, NEW YORK 12866

518.306.5233

ALBANY COUNTY SHERIFF-CLARKSVILLE-FURNITURE BUDGET

Item	Qty.	MFG.	Model #		Unit	Price Extended
			~	Undecided LAMINATE Option		
40	1	HON	HNL3672LPRB	72x36x29-1/2 Lf Ped Desk rect top bkft mod	\$816.15	\$816.15
	120		.G	Smooth, Flat		
			~	Undecided EDGE Option		
			~	Undecided PULL Option		
			~	Undecided GROMMET Option		
			\$(L1STD)	Grd L1 Standard Laminates		
			~	Undecided LAMINATE Option		
			\$(L1STD)	Grd L1 Standard Laminates		
			~	Undecided LAMINATE2 Option		
			\$(L1STD)	Grd L1 Standard Laminates		
			~	Undecided COLOR Option		
41	4	HON	HIGS6	Ignition Guest/Multi-Purpose Chair Four-Leg Stacking	\$181.97	\$727.88
	120		.N	Arm: Armless		
			.H	Hard		
			.U	Back: Upholstered		
			~	Undecided FABRIC Option		
			~	Undecided FRAME Option		
42	1	HON	HML1S	Grove Single Seat Lounge	\$740.39	\$740.39
	120		.B	Arm: Tapered		
			\$(2)	Grade 2 Upholstery		
			.WP	Whisper Vinyl		
			~	Undecided FABRIC Option		



BUSINESS INTERIORS

153 REGENT STREET

SARATOGA SPRINGS, NEW YORK 12866

518.306.5233

ALBANY COUNTY SHERIFF-CLARKSVILLE-FURNITURE BUDGET

Item	Qty.	MFG.	Model #		Unit	Price Extended
			.TS	Tapered Square Leg		
			~	Undecided COLOR Option		
43	1	HON	HTLD36	Preside 36" Round Shaped Laminate Top	\$182.36	\$182.36
	120		.G	2MM/Flat		
			~	Undecided EDGE Option		
			.N	No Grommets		
			\$(L1STD)	Grd L1 Standard Laminates		
			~	Undecided LAMINATE Option		
44	1	HON	HTXLEG	Preside Aluminum X-Leg	\$222.98	\$222.98
	120		\$(P1)	P1 Paint Opts		
			~	Undecided PAINT Option		
45	10	HON	HIGS6	Ignition Guest/Multi-Purpose Chair Four-Leg Stacking	\$196.03	\$1,960.30
	122		.N	Arm: Armless		
			.H	Hard		
			.U	Back: Upholstered		
			\$(2)	GRADE: II UPHOLSTERY		
			~	Undecided FABRIC Option		
			~	Undecided FRAME Option		
46	10	HON	HIGS6	Ignition Guest/Multi-Purpose Chair Four-Leg Stacking	\$207.75	\$2,077.50
	122		.F	Arm: Fixed		
			.H	Hard		
			.U	Back: Upholstered		
			\$(2)	GRADE: II UPHOLSTERY		



BUSINESS INTERIORS

153 REGENT STREET

SARATOGA SPRINGS, NEW YORK 12866

518.306.5233

ALBANY COUNTY SHERIFF-CLARKSVILLE-FURNITURE BUDGET

Item	Qty.	MFG.	Model #		Unit	Price Extended
			~	Undecided FABRIC Option		
			~	Undecided FRAME Option		
47	2	HON	HTG2PWR-4P-2B	ElloraB G2 Fiptop Port-4 AC Pwr-2 Blank-10' Cord	\$244.45	\$488.90
	122		.SVR	Silver		
48	1	HON	HTLB48120	Preside 120W x 48D Boat Shaped Laminate Top	\$492.81	\$492.81
	122		.G	2MM/Flat		
			~	Undecided EDGE Option		
			.G2	Cut out for Flip Top Port		
			\$(L1STD)	Grd L1 Standard Laminates		
			~	Undecided LAMINATE Option		
49	1	HON	HTLCRED72	Preside 20x72 36H Hospitality Credenza	\$1,180.48	\$1,180.48
	122		\$(L1STD)	Gr L1 Standard Laminates		
			~	Undecided LAMINATE Option		
			~	Undecided EDGE Option		
			\$(L1STD)	Gr L1 Standard Laminates		
			~	Undecided LAMINATE Option		
			~	Undecided PULL Option		
			.N	No Cutout		
50	1	HON	HTLHP120	Preside Laminate Hollow Panel Base For 120" W Table Tops	\$775.92	\$775.92
	122		\$(L1STD)	Grd L1 Standard Laminates		
			~	Undecided LAMINATE Option		
			~	Undecided LAMINATE2 Option		



BUSINESS INTERIORS

153 REGENT STREET

SARATOGA SPRINGS, NEW YORK 12866

518.306.5233

ALBANY COUNTY SHERIFF-CLARKSVILLE-FURNITURE BUDGET

Item	Qty.	MFG.	Model #		Unit	Price Extended
51	2	HON	H10502	10500 Series Floorstnd Full Ht Ped B/B/F 15-5/8W x 22-3/4D	\$284.28	\$568.56
			123-124	\$(L1STD) Grd L1 Standard Laminates		
				~ Undecided LAMINATE Option		
52	2	HON	H105535	10500 Series Bookcase 5-shelf 36Wx13-1/8Dx71H	\$341.69	\$683.38
			123-124	\$(L1STD) Grd L1 Standard Laminates		
				~ Undecided LAMINATE Option		
53	1	HON	H105907R	10500 Series 42Wx24Dx29-1/2H Return Rt File/File Ped	\$389.72	\$389.72
			123-124	\$(L1STD) Grd L1 Standard Laminates		
				~ Undecided LAMINATE Option		
54	1	HON	H105908L	10500 Series 42Wx24Dx29-1/2H Return Lt File/File Ped	\$389.72	\$389.72
			123-124	\$(L1STD) Grd L1 Standard Laminates		
				~ Undecided LAMINATE Option		
55	2	HON	H10592	10500 Series Desk Shell 72W x 30D x 29-1/2H	\$316.70	\$633.40
			123-124	\$(L1STD) Grd L1 Standard Laminates		
				~ Undecided LAMINATE Option		
56	2	HON	H1522	Wood Center Drawer 22W x 15-3/8D	\$77.71	\$155.42
			123-124	\$(L1STD) Grd L1 Standard Laminates		
				~ Undecided LAMINATE Option		
57	4	HON	HIGS6	Ignition Guest/Multi-Purpose Chair Four-Leg Stacking	\$207.75	\$831.00
			123-124	.F Arm: Fixed		



BUSINESS INTERIORS

153 REGENT STREET

SARATOGA SPRINGS, NEW YORK 12866

518.306.5233

ALBANY COUNTY SHERIFF-CLARKSVILLE-FURNITURE BUDGET

Item	Qty.	MFG.	Model #		Unit	Price Extended
			.H	Hard		
			.U	Back: Upholstered		
			\$(2)	GRADE: II UPHOLSTERY		
			~	Undecided FABRIC Option		
			~	Undecided FRAME Option		
58	1	HON	H10502	10500 Series Floorstnd Full Ht Ped B/B/F 15-5/8W x 22-3/4D	\$284.28	\$284.28
	125		\$(L1STD)	Grd L1 Standard Laminates		
			~	Undecided LAMINATE Option		
59	1	HON	H10504	10500 Series Floorstnding Full Ht Ped F/F 15-5/8W x 22-3/4D	\$284.28	\$284.28
	125		\$(L1STD)	Grd L1 Standard Laminates		
			~	Undecided LAMINATE Option		
60	1	HON	H10578X	10500 Series 60Wx30Dx29-1/2H Desk Shell-Rec Top 2'grm	\$279.21	\$279.21
	125		\$(L1STD)	Grd L1 Standard Laminates		
			~	Undecided LAMINATE Option		
61	1	HON	H1522	Wood Center Drawer 22W x 15-3/8D	\$77.71	\$77.71
	125		\$(L1STD)	Grd L1 Standard Laminates		
			~	Undecided LAMINATE Option		
62	3	HON	H10502	10500 Series Floorstnd Full Ht Ped B/B/F 15-5/8W x 22-3/4D	\$284.28	\$852.84
	126-128		\$(L1STD)	Grd L1 Standard Laminates		
			~	Undecided LAMINATE Option		
63	2	HON	H105907R	10500 Series 42Wx24Dx29-1/2H Return Rt File/File Ped	\$389.72	\$779.44
	126-128					



BUSINESS INTERIORS

153 REGENT STREET

SARATOGA SPRINGS, NEW YORK 12866

518.306.5233

ALBANY COUNTY SHERIFF-CLARKSVILLE-FURNITURE BUDGET

Item	Qty.	MFG.	Model #		Unit	Price Extended
			\$(L1STD)	Grd L1 Standard Laminates		
			~	Undecided LAMINATE Option		
64	1	HON	H105908L	10500 Series 42Wx24Dx29-1/2H Return Lt File/File Ped	\$389.72	\$389.72
			126-128			
			\$(L1STD)	Grd L1 Standard Laminates		
			~	Undecided LAMINATE Option		
65	3	HON	H10592	10500 Series Desk Shell 72W x 30D x 29-1/2H	\$316.70	\$950.10
			126-128			
			\$(L1STD)	Grd L1 Standard Laminates		
			~	Undecided LAMINATE Option		
66	3	HON	H1522	Wood Center Drawer 22W x 15-3/8D	\$77.71	\$233.13
			126-128			
			\$(L1STD)	Grd L1 Standard Laminates		
			~	Undecided LAMINATE Option		
67	3	HON	H9190A	Flagship 42W 2-Drw "A" Pull Lateral 42W 28H 18D	\$528.33	\$1,584.99
			126-128			
			.L	Standard Random Key Lock		
			\$(P1)	P1 Paint Opts.		
			~	Undecided PAINT Option		
68	12	HON	H919492	Double Rail Hanging File Racks(2 Pack)	\$27.79	\$333.48
			126-128			
69	1	OFS	3515	Revel, Executive Back	\$694.45	\$694.45
			120			
			CR13	4D Pivoting Arms		
			W48	Black Hard Wheel Caster - Std		
			BDB3	Body Balance		
			SS3	Seat Slider		



BUSINESS INTERIORS

153 REGENT STREET

SARATOGA SPRINGS, NEW YORK 12866

518.306.5233

ALBANY COUNTY SHERIFF-CLARKSVILLE-FURNITURE BUDGET

Item	Qty.	MFG.	Model #		Unit	Price Extended
			TT	Standard Black Nylon Base		
			L1	Grade L1 Leather		
			BASL1	Helvetia Basic Leather		
			3068770	Black BA90		
			KND	Knocked Down		
70	2	SAF	5285	Wire Shelving Starter Unit, 18 x 36"	\$285.19	\$570.38
	117		GR	Gray		
71	2	SAF	5286	Wire Add-On Unit, 18 x 36"	\$270.00	\$540.00
	117		BL	Black		
72	4	SIT	2223.B1.F.A128	Wit Task, Highback, Mesh Back, Standard Synchro, Height Adj Arms	\$208.80	\$835.20
	103 105 106 107		~	No Seat Depth Adjustment Upgrade		
			...	Skipped Option		
			...	Skipped Option		
			FABRIC	Fabric Grade Selections		
			~	No Selection		
			FG2	Fabric Grade 2		
			~	No Selection		
			TOR			
			KD	Knocked Down		
73	1	SIT	2223.B1.F.A128	Wit Task, Highback, Mesh Back, Standard Synchro, Height Adj Arms	\$208.80	\$208.80
	108		~	No Seat Depth Adjustment Upgrade		
			...	Skipped Option		
			...	Skipped Option		



BUSINESS INTERIORS

153 REGENT STREET

SARATOGA SPRINGS, NEW YORK 12866

518.306.5233

ALBANY COUNTY SHERIFF-CLARKSVILLE-FURNITURE BUDGET

Item	Qty.	MFG.	Model #		Unit	Price Extended
			FABRIC	Fabric Grade Selections		
			~	No Selection		
			FG2	Fabric Grade 2		
			~	No Selection		
			TOR			
			KD	Knocked Down		
74	1	SIT	2223.B1.F.A128	Wit Task, Highback, Mesh Back, Standard Synchro, Height Adj Arms	\$208.80	\$208.80
	109		~	No Seat Depth Adjustment Upgrade		
			...	Skipped Option		
			...	Skipped Option		
			FABRIC	Fabric Grade Selections		
			~	No Selection		
			FG2	Fabric Grade 2		
			~	No Selection		
			TOR			
			KD	Knocked Down		
75	8	SIT	971.S2	Inflex, Plastic Seat & Back, Bar Stool, Armless	\$168.48	\$1,347.84
	110		SC5	Navy		
			~	No Selection		
			FC2	Silver		
			G12	Floor Saver Glide		
			AC	Fully Assembled in a Carton		
76	43	SIT	974	Inflex, Plastic Seat & Back, Side Chair, Casters, Armless	\$137.16	\$5,897.88
	121					



BUSINESS INTERIORS

153 REGENT STREET

SARATOGA SPRINGS, NEW YORK 12866

518.306.5233

ALBANY COUNTY SHERIFF-CLARKSVILLE-FURNITURE BUDGET

Item	Qty.	MFG.	Model #		Unit	Price Extended
			SC5	Navy		
			~	No Selection		
			FC2	Silver		
			C12	Hard Floor and Carpet Casters		
			AC	Fully Assembled in a Carton		
77	2	SIT	2223.B1.F.A128	Wit Task, Highback, Mesh Back, Standard Synchro, Height Adj Arms	\$208.80	\$417.60
			123-124			
			~	No Seat Depth Adjustment Upgrade		
			...	Skipped Option		
			...	Skipped Option		
			FABRIC	Fabric Grade Selections		
			~	No Selection		
			FG2	Fabric Grade 2		
			~	No Selection		
			TOR			
			KD	Knocked Down		
78	3	SIT	2222.B1.B.S2	Wit Task, Midback, Extended Stool Kit, Mesh Back, Basic, Armless	\$232.20	\$696.60
			125			
			FC1	Black		
			Z2	Silver		
			B0	Standard Black Base		
			C17	Hard Floor and Carpet Casters		
			MC20	Onyx		
			FABRIC	Fabric Grade Selections		
			~	No Selection		
			FG2	Fabric Grade 2		



BUSINESS INTERIORS

153 REGENT STREET

SARATOGA SPRINGS, NEW YORK 12866

518.306.5233

ALBANY COUNTY SHERIFF-CLARKSVILLE-FURNITURE BUDGET

Item	Qty.	MFG.	Model #		Unit	Price Extended
			~	No Selection		
			TOR			
			KD	Knocked Down		
79	1	SIT	2223.B1.F.A128	Wit Task, Highback, Mesh Back, Standard Synchro, Height Adj Arms	\$223.20	\$223.20
	125		~	No Seat Depth Adjustment Upgrade		
			FC1	Black		
			Z2	Silver		
			~	Black Arm		
			B0	Standard Black Base		
			S0	Standard Cylinder		
			C17	Hard Floor and Carpet Casters		
			MC20	Onyx		
			FABRIC	Fabric Grade Selections		
			~	No Selection		
			FG2	Fabric Grade 2		
			~	No Selection		
			TOR			
			KD	Knocked Down		
80	3	SIT	2223.B1.F.A128	Wit Task, Highback, Mesh Back, Standard Synchro, Height Adj Arms	\$208.80	\$626.40
	126-128		~	No Seat Depth Adjustment Upgrade		
			...	Skipped Option		
			...	Skipped Option		
			FABRIC	Fabric Grade Selections		
			~	No Selection		



BUSINESS INTERIORS

153 REGENT STREET

SARATOGA SPRINGS, NEW YORK 12866

518.306.5233

ALBANY COUNTY SHERIFF-CLARKSVILLE-FURNITURE BUDGET

Item	Qty.	MFG.	Model #		Unit	Price Extended
			FG2	Fabric Grade 2		
			~	No Selection		
			TOR			
			KD	Knocked Down		
81	1	drb	D&I	Inside Delivery-Receive, deliver and install all product and discard packaging.	\$8,972.00	\$8,972.00

Total: \$58,341.70

This is just a QUOTE:

Need to have updated before placing any orders with appropriate vendor information.

50% deposit required to process order, unless State Contract.

Quote does not include applicable sales tax.

Please be sure that a signature is on the PO.

Please be sure to fax both your PO and this signed quote to my attention @ (518) 306-5256 for processing.

Sending your PO to the MFG will not result in an order.

NO RETURNS OR EXCHANGES WILL BE ACCEPTED

X _____ X _____

Signature

Date

Please sign, approving quantities, descriptions, finishes and payment terms.

Albany County Request for Contract Approval

Contract #	2022-262
Contract Type	B) CAB Contract
Contract Action	A) New
Contract Action Type	A) New
Department	NH6020 - Residential Health Care Facility
Date Submitted	Monday, April 11, 2022
Contact Person	Coffey, Thomas
Contact Phone	1 (518) 213-8937
Vendor Info	Eklego Workforce Solutions 110 Marina Drive, Rochester, New York 14626
Estimated Amount	\$99,500.00
Estimated Term	4/25/2022 to 4/24/2023
Scope of Services	The firm will provide recruitment services of viable candidates to be considered for vacant positions, on an as needed basis, as determined by the Administration at the facility. The firm will develop a strategic recruitment plan for the selection, hiring and retention of the employees needed to be hired. In doing so, the consultant/firm will place advertisements in appropriate publications/online, initial screening of all candidates, resume review, eligibility determination, background/reference checking, credential verification, initial interviewing and scheduling of interview follow-up with facility staff.
Budget Line Item	NH6020 - 44069 - - -
Fiscal Impact	County: 100.00% State: 0.00% Federal: 0.00% Local: 0.00% Other: 0.00%
BID, RFP, RFQ Completed?	Yes - RFP

Budget Analyst

Date

For Contract Board Use:

Date Approved

Daniel P. McCoy
Albany County Executive

Bruce A. Hidley
Albany County Clerk

Andrew Joyce, Chairman
Albany County Legislature



Daniel P. McCoy
County Executive

Larry I. Slatky
Executive Director

TO: The Honorable Daniel P. McCoy
 Albany County Executive

 The Honorable Andrew Joyce
 Chairman, Albany County Legislature

 The Honorable Bruce Hidley
 Albany County Clerk

FROM: Larry Slatky
 Executive Director,
 Shaker Place Rehabilitation and Nursing Center.

DATE: April 14, 2022

SUBJECT: Eklego Workforce Solutions

Shaker Place Rehabilitation and Nursing Center respectfully requests to enter into an agreement with Eklego Workforce Solutions. The contract period will be from April 25, 2022 to April 24, 2023 for an amount not to exceed \$99,500.00.

Eklego Workforce Solutions was chosen through the RFP process and was the lowest responsible bidder. The firm will provide recruitment services of viable candidates to be considered for vacant positions. They will assist Shaker Place in developing a strategic recruitment plan for the hiring and retention of staff. They will be responsible to place advertisement in publications, conduct initial screening of candidates, background checks, references and credential verification.

Shaker Place will pay a monthly management fee, a fee for each staff member hired, and an additional fee for key personnel which will be a percentage of the annual salary.

We respectfully request approval to enter into an agreement with Eklego Workforce Solutions.





DANIEL P. McCOY
COUNTY EXECUTIVE

COUNTY OF ALBANY
DEPARTMENT OF GENERAL SERVICES
PURCHASING DIVISION
112 STATE STREET, ROOM 1000
ALBANY, NEW YORK 12207-2021
(518) 447-7140 - FAX (518) 447-5588

DAVID M. LATINA
COMMISSIONER OF GENERAL SERVICES

KAREN A. STORM
PURCHASING AGENT

MEMORANDUM

TO: Larry Slatky
Shaker Place Rehabilitation and Nursing Center

FROM: Karen Storm *K Storm*
Purchasing Agent

DATE: April 11, 2022

RE: RFP #2022-034, Recruiting Consultant

I am in receipt of your recommendation to award the aforementioned Request for Proposals to Eklego Workforce Solutions.

I have reviewed your scoring sheets and believe that you have performed a thorough evaluation of the proposals submitted. I have no objection to the selection of Eklego Workforce Solutions for an award.

Please obtain the necessary contract approval of the Contract Administration Board, so that we may issue a Notice of Award to the successful proposer.

Shaker Place Rehabilitation and Nursing Center
RFP #2022-034
Recruiting Consultant

Shaker Place (SP) received a total of four (4) proposals in response to the Request for Proposals (RFP) for Recruiting Consultant. The proposals were reviewed by SP staff members, Thomas Coffey, Administrator, Frank Commisso, Director of Fiscal Operations and Laura Vartanian, RN. The Committee's rating sheets, reflecting the individual evaluations of each committee member, accompany this document. Below, are the consensus comments of the Committee as they pertain to the proposals, as well as the Committee's final recommendation for award of the contract.

Comments:

Our current environment is faced with a national healthcare worker shortage. Our collective efforts to date have not afforded us with the necessary staffing complement or access to the said workforce and we find it necessary to seek additional resources to connect with the qualified staff required to meet the clinical needs of our residents. We recognize that we are competing for these staff members with the many hospitals, nursing facilities and independent healthcare settings in our community and beyond. As such, it is incumbent upon ourselves to engage a professional recruitment firm to augment our outreach.

All four (4) firms demonstrated in their proposal the capability to meet the Scope of Services as outlined in the RFP. It is clearly evident that each firm has the professional qualifications and experience necessary to provide employment recruiting services for the purposes of supplying direct placement services for health care management and hard to fill positions. The proposed cost of each firm was the determining factor in the evaluative process. The Proposed Cost, as represented on our individual Rating Worksheets, has a weighted effect of 25% of the overall score determining the recommendation for awarding of the contract. The proposals were evaluated based on the prospective annual cost to Shaker Place to secure the employment of our current and prospective vacancies in healthcare management and hard to fill positions as identified by Administration.

The firm that we are recommending was the lowest annual cost proposal of the four proposals that were submitted for consideration. Additionally, this firm works exclusively in senior care helping organizations recruit and hire their workforce. Our committee contacted the references provided and found that this firm has maintained a positive working relationship with them and generated the results requested by the respective healthcare facility.

Upon review of the four (4) proposals, the committee is recommending that the contract be awarded to Eklego Workforce Solutions.

RFP #2022-034: Recruiting Consultant

Proposal Rating Worksheet

Proposer: Eklego

	Weight	Tom Coffey		Frank Commisso		Laura Vartanian		Reviewer 4	
		Rate	Score	Rate	Score	Rate	Score	Rate	Score
Quality and Comprehensiveness of all aspects of the consulting services as it is related to the stated scope of	30%	4	1.2	4	1.2	4	1.2		0
Demonstrated history of providing services for health care providers as stated in the scope of services	35%	5	1.75	4	1.4	5	1.75		0
Proposed Cost.	25%	5	1.25	5	1.25	5	1.25		0
Client references.	10%	5	0.5	5	0.5	5	0.5		0
TOTALS:			4.7		4.35		4.7		0

Avg 4.58

NOTES:

RFP #2022-034: Recruiting Consultant

Proposal Rating Worksheet

Proposer: Talent4Health

	Weight	Tom Coffey		Frank Comisso		Laura Vartanian		Reviewer 4	
		Rate	Score	Rate	Score	Rate	Score	Rate	Score
Quality and Comprehensiveness of all aspects of the consulting services as it is related to the stated scope of	30%	4	1.2	4	1.2	4	1.2		0
Demonstrated history of providing services for health care providers as stated in the scope of services	35%	5	1.75	4	1.4	5	1.75		0
Proposed Cost.	25%	4	1	3	0.75	4	1		0
Client references.	10%	5	0.5	5	0.5	5	0.5		0
TOTALS:			4.45		3.85		4.45		0

Avg 4.25

NOTES:

RFP #2022-034: Recruiting Consultant

Proposal Rating Worksheet

Proposer: Infojini

	Weight	Tom Coffey		Frank Comisso		Laura Vartanian		Reviewer 4	
		Rate	Score	Rate	Score	Rate	Score	Rate	Score
Quality and Comprehensiveness of all aspects of the consulting services as it is related to the stated scope of	30%	5	1.5	4	1.2	4	1.2		0
Demonstrated history of providing services for health care providers as stated in the scope of services	35%	5	1.75	4	1.4	5	1.75		0
Proposed Cost.	25%	3	0.75	2	0.5	3	0.75		0
Client references.	10%	5	0.5	5	0.5	5	0.5		0
TOTALS:			4.5		3.6		4.2		0

Avg 4.1

NOTES:

RFP #2022-034: Recruiting Consultant

Proposal Rating Worksheet

Proposer: Medlink Health

	Weight	Tom Coffey		Frank Commisso		Laura Vartanian		Reviewer 4	
		Rate	Score	Rate	Score	Rate	Score	Rate	Score
Quality and Comprehensiveness of all aspects of the consulting services as it is related to the stated scope of	30%	5	1.5	4	1.2	5	1.5		0
Demonstrated history of providing services for health care providers as stated in the scope of services	35%	5	1.75	4	1.4	3	1.05		0
Proposed Cost.	25%	2	0.5	1	0.25	2	0.5		0
Client references.	10%	5	0.5	5	0.5	5	0.5		0
TOTALS:			4.25		3.35		3.55		0

Avg 3.72

NOTES:



**Request for Proposal #2022-034
RECRUITING CONSULTANT**

Eklego Workforce Solutions
110 Marina Drive
Rochester, NY 14626

Tony Coccitto
President
585.230.6658

TABLE OF CONTENTS

- Section I
 - Cover Page – page 1
 - Table of Contents – page 2
- Section II
 - Qualification/Experience – page 3
 - Resumes – page 3 (and attached)
- Section III
 - References – page 3
- Section IV
 - Plan of Implementation – pages 3-5
- Section V
 - Cost Proposal – pages 5-6
- Section VI
 - Mandatory Documentation – page 6 (and attached)



Section II

Qualification of Eklego Workforce Solutions

Eklego Workforce Solutions is a senior care workforce solutions company. Eklego works exclusively in senior care helping organizations recruit, hire, and sustain a mission-driven workforce. Based in Rochester, NY, Eklego partners with senior care organizations in over 15 states, including partners throughout the state of New York. Eklego has been serving the senior care industry since 2006 and has helped our partners make over 7,000 hires in 2021. Eklego provides workforce consulting, recruitment process outsourcing, and professional and clinical search services.

Resumes

Profiles of Tony Coccitto, President and Holly Eschberger, Vice President of Operations attached.

Section III

Client References

Dutch Hayward, COO
Wesley Community
131 Lawrence St.
Saratoga Springs, NY 12866
(518) 691-1402

Mike Perrotta, Vice President
Friendly Senior Living
3156 East Ave.
Rochester, NY 14618
(585) 703-2995

Section IV

Implementation Plan

Upon receiving final approval from Shaker Place, Eklego will initiate the partnership implementation process. Holly Eschberger, Vice President of Operations, will lead



implementation, working closely with Shaker Place key stakeholders. This process will take up to 4 weeks and predicated on receiving necessary items and communication from Shaker Place.

Sample Implementation task list:

New Partner Implementation Worksheet			
Launch Date:			
Main Client Contact(s):			
Hiring Process Flow			
Kick off meeting date:			
Organizational Intake call scheduled:			
Hiring Manager (HM) Intakes:			
HR/HM ATS Training: First 2 days after launch			
Process Details: Need from HR	Who	Deadline	Completed By
Requisition Form			
Application			
References (requirements)			
ATS Users/Job Title and Contact Info			
Departments			
Job Titles			
Shifts			
Declination Letter			
Disqualifcation Reasons			
Payrates/Shift Diffs			
FEIN #			
Benefits Info			
Logo/Artwork			
Candidate Interview Reporting Instructions			
EEO Statement			
Internal Job Numbers (if you utilize them)			
Employee Referral Program			
Current Sourcing Contacts/Networks			
Internal and Former Employees Process			
Offer process			
Job Descriptions for all open positions			

Client email account for recruitment			
LinkedIn page info for indexing			
Marketing Contact (for social media requests, etc)			
Social Media "How" - requests, charge backs			
HRIS linking			

Section V

Cost Proposal

SERVICES

Recruitment Process Outsourcing

Eklego provides full recruitment services for Client for the hiring of all positions below Director level. Services to include

Applicant Tracking System:

- A. Eklego will furnish Client with a customized applicant tracking system (ATS). The ATS is designed to support the recruitment program and allow Client to be linked to Eklego's recruitment activity.
- B. **Requisition:**
Upon receipt of approved requisition from Client Human Resources, Eklego will conduct a position intake with Client to ensure hiring criteria is established.
- C. **Sourcing & Recruitment Implementation:**
Eklego will post open position in the ATS and will be indexed to over 20 job boards. Candidate search licenses for Indeed and ZipRecruiter, and other free recruitment sources. Any additional fee-based sourcing must be approved by Client and will be billed at cost.
- D. **Candidate Pre-Screening:**
Candidates will be reviewed and screened by Eklego to determine job fit (review licensure/certification if applicable, work history, skills, experience, location, hours, and availability).
- E. **Interview Scheduling:**
Eklego will coordinate interviews between candidates and Hiring Managers using predetermined times provided by Client.
- F. **On-Boarding:**
Eklego will provide reference checks on selected candidates.

G. Director or "Specialized Search" Positions

Client has the option to engage Eklego on all Director Level or specialized positions. The recruitment fee will be 15% of hired employee's annual salary.

Billing will occur at four search milestones: 25% at search engagement, 25% at interview conducted, 25% at job offer, 25% when employee starts employment. Eklego will provide a six-month replacement guarantee on all specialized search engagements.

SERVICE METRICS & REPORTING

Eklego to provide weekly dashboard report to include the following:

- I. Current open positions being recruited
- II. Number of scheduled interviews
- III. Number of offers
- IV. Number of pending starts
- V. Number of filled positions

Eklego to provide quarterly analytics to key stakeholder to enhance partnership and equip Client with actionable items when it comes to recruitment and hiring.

Eklego to also provide regular feedback and recommendations to Client on the marketplace related to their open positions. Goal would be to assist Client in attracting and engaging hireable candidates.

FEES

Monthly Service Fees: \$5,000.00

\$500.00 per hire

Invoices to be paid by the 5th of each month and payable to:

Eklego Workforce Solutions
110 Marina Drive
Rochester, NY 14626

Section VI

Mandatory documentation forms attached.

Tony Coccitto, PHR

Summary:

With over 25 years of recruitment and business relationship experience, my focus is developing partnerships with senior care organizations to help them attract, hire, and build a mission-minded workforce. Our purpose at Eklego is to have a profound impact on our client's ability to attract talent that will support their mission of serving elders.

Experience:

Eklego Workforce Solutions

5 years 3 months

President

January 2021 - Present (1 year 3 months) Rochester, New York Metropolitan Area

As the President, I work closely with leaders in Senior Care to help improve their ability to attract, hire, and retain a mission-driven workforce. Leveraging over 25 years of recruitment and business relationship experience, my fundamental goal is to help our partners achieve their strategic workforce goals.

Vice President

January 2017 - December 2020 (4 years) Rochester, NY

St. Ann's Community

Executive Director of Strategic Partnerships June 2015 - January 2017 (1 year 8 months) Rochester, NY

As the Executive Director of Strategic Partnerships, my focus was building business relationships that advance the St. Ann's Mission & Brand. St. Ann's Community is the third largest healthcare system in Rochester with \$85 million in revenues and the 20th largest private employer.

Working in concert with the senior leadership team, I provided a strategic plan to identify future customers, health partners, and market opportunities that support the strategic growth of St. Ann's Community. The goal was to advance and elevate St. Ann's value proposition to key external stakeholders making the organization "Top of Mind" at partner organizations.

The Premier Partners

Managing Partner

September 2004 - May 2015 (10 years 9 months) Rochester, NY

As a Managing Partner with The Premier Partners, my focus was working with executives in senior living to help them reduce staff vacancy and turnover. Whether the organization desired system-wide or targeted recruitment solutions, I helped implement a sustainable recruitment, selection, and hiring system.

Premier has filled over 5,000 healthcare positions in 2014; we've helped our clients drive down workforce costs by an average of \$200,000/year; we have reduced the time to fill positions by an average of 45%; and our partners experience an increase of applicant flow by 3x.

Ablest Staffing

Area Manager

October 1997 - September 2004 (7 years)

Rochester, NY

As an Area Manager for a national staffing company, my focus was developing client partnerships while building and developing a winning service team.

We have helped organizations with their flexible staffing needs and targeted professional searches.

Our branch was awarded with multiple Service Excellence awards and I had the honor to be a three time national Star Performer for Ablest.

Interim Personnel

Sales Representative - Branch Manager September 1993 - May 1997 (3 years 9 months) Baltimore, Maryland

As a Sales Representative for a national staffing company, I was responsible for business development in the Baltimore market. We offered contract staffing and professional search services. Organizations depended on our team's ability to fill positions in a timely manner with people possessing the right skills, attitudes, and motivation.

During my last six months before relocating, I served as the Branch Manager having the overall responsibility of the operation's performance and profitability.

Education

Alfred University

Bachelor's Degree, Business Administration and Marketing · (1988 - 1992)

Brockport High School

High School Diploma, Business Administration · (1985 - 1988)

Holly Eschberger

Summary

Over 25 years of innovative recruiting and customer service experience focused on Client Relations, Strategic and Creative Talent Acquisition, and Workforce Development and Consulting. My focus has been and continues to be on building valuable partnerships with Senior Care, Healthcare and Non-Profit Organizations to complement and enhance existing practices to attract, hire and engage a mission minded workforce.

Experience:

Eklego Workforce Solutions

6 years 3 months

Vice President of Operations 2019 - Present (3 years) Rochester, NY

Senior Director of Client Services

2017 - 2019 (2 years)

Rochester, New York Area

Director of Client Services

January 2016 - 2017 (1 year)

Rochester, New York Area

As the Director of Client Services, I work collaboratively with our mission- minded clients and our dedicated internal team to implement, maintain and enhance service levels of our proven recruitment and hiring model.

The Premier Partners

Director of Client Services

June 2003 - December 2016 (13 years 7 months) Rochester, NY

Adecco

Branch Manager

1996 - 2002 (6 years)

Education:

St. John Fisher College

BA, English

Hornell

High School Diploma · (1990)

Hilbert College

AAS, Human Services

COUNTY OF ALBANY

REQUEST FOR PROPOSALS

SHAKER PLACE REHABILITATION AND NURSING CENTER



RFP # 2022-034

RECRUITING CONSULTANT

**ALBANY COUNTY DEPARTMENT OF GENERAL SERVICES
PURCHASING DIVISION
KAREN A. STORM, PURCHASING AGENT
112 STATE STREET, ROOM 1000
ALBANY, NY 12207**

COUNTY OF ALBANY
REQUEST FOR PROPOSALS
RECRUITING CONSULTANT
SHAKER PLACE REHABILITATION AND NURSING CENTER
RFP #2022-034

RFP DISTRIBUTION- IMPORTANT NOTICE

The County of Albany officially distributes RFP documents through the Purchasing Division Office or through the Empire State Bid System website at <http://www.empirestatebidsystem.com>. Copies of RFP documents obtained from any other source are not considered official documents. Only those vendors who obtain proposal documents from either the Purchasing Division Office or the Empire State Bid System are guaranteed to receive addendum information, if such information is issued.

If you have obtained this document from a source other than the Albany County Purchasing Division or the Empire State Bid System, it is strongly recommended that you obtain an official copy.

SECTION 1: PURPOSE

- 1.1 The County of Albany is seeking proposals for a **Recruiting Consultant** as requested by the **Albany County Shaker Place Rehabilitation and Nursing Center**.
- 1.2 Shaker Place Rehabilitation and Nursing Center (Shaker Place) is seeking proposals for a consultant/firm to provide employment recruiting services for the purposes of supplying direct placement services for health care management and hard to fill positions.

SECTION 2: RECEIPT OF PROPOSALS

- 2.1 Five (5) copies, and (1) electronic copy on CD or flash drive, of the Proposal and other required documents must be submitted, sealed in an opaque envelope clearly marked with the name and number of the Proposal and the name and address of the Proposer. Proposals must be received no later than **4:30 P.M. on FRIDAY, MARCH 25, 2022**, at the following address:

Karen A. Storm
Albany County Purchasing Agent
112 State Street, **Room 1000**
Albany, New York 12207

- 2.2 The Proposal submitted by the individual Proposer(s) is the document upon which Albany County will make its initial judgment regarding the Proposer's qualifications, understanding of the County's scope and objectives, methodology, and ability to complete services under the contract.

- 2.3 Those submitting Proposals do so entirely at their expense. There is no express or implied obligation by Albany County to reimburse any firm or individual for any costs incurred in preparing or submitting Proposals, preparing or submitting additional information requested by the County, or for participating in any selection interviews.
- 2.4 Submission of any Proposal indicates acceptance of the conditions contained in the RFP, unless clearly and specifically noted otherwise in the Proposal.
- 2.5 Albany County reserves the right to reject any and all Proposals, in whole or in part, submitted in response to its RFP.
- 2.6 Albany County reserves the right to waive any and all informalities and to disregard all non-conforming, non-responsive or conditional Proposals.
- 2.7 Albany County may, at any time by written notification to all Proposers, change any portion of the RFP described and detailed herein.
- 2.8 Proposals will be examined and evaluated by the **Shaker Place Rehabilitation and Nursing Center**.
- 2.9 During the evaluation of Proposals, the County may require clarification of information or may invite Proposers to an oral presentation to amplify and or validate Proposal contents.

SECTION 3: QUALIFICATION OF PROPOSER

Provide a statement of Proposer qualifications including:

- 3.1 Provide the name, a brief history and description of your firm.
- 3.2 Identify your firm's professional staff members who will be involved in the County engagement and the experience each possesses and the location of the office from which each work.
- 3.3 Name and title of person(s) authorized to bind the Proposer, together with the main office address, and telephone number (including area code).
- 3.4 Detail your firm's experience with recruitment consulting.
- 3.5 Provide at least two (2) references from similar projects including name, addresses and telephone numbers.
- 3.6 Provide any additional information that would distinguish your firm in its service to Albany County.

- 3.7 Proposer shall include a completed “Vendor Responsibility Questionnaire” (Attachment “C”) with the Proposal.
- 3.8 In addition, Albany County may make such investigations it deems necessary to determine the ability of the Proposer to perform the work. The Proposer shall furnish to the County , within five (5) days of a request, all such information and data for this purpose as may be requested. The County reserves the right to reject any Proposal if the information submitted by, or investigation of, such Proposer fails to satisfy the County that such Proposer is properly qualified to carry out the obligations of the contract and to complete the work contemplated therein. Conditional Proposals will not be accepted.

SECTION 4: SCOPE OF SERVICES

- 4.1 Shaker Place Rehabilitation and Nursing Center (Shaker Place) is seeking proposals for a consultant/firm to provide employment recruiting services for the purposes of supplying direct placement services for health care management and hard to fill positions.

The proposals are for a consultant/firm to provide recruitment services of strong viable candidates to be considered for vacant positions on an as needed basis. Shaker Place is interested in receiving competitive price quotes documenting the firm’s ability to provide this recruitment service. The documentation should include an overview of the history and experience of the firm.

In consultation with Shaker Place management, the consultant/firm will meet with administrative staff at the facility in advance of any employment recruitment in order to understand the employment needs, the job requirements of the positions sought to be filled and to develop a strategic recruitment plan for the selection, hiring and retention of the employee(s) for the position(s) identified by Shaker Place.

There continues to be a variety of clinical healthcare positions that place challenges on the County to fill as they become vacant. In particular, the health care positions require specific certifications, licensure and skills to be considered. The nursing home industry has a myriad of technical clinical roles that, in addition to required certification, also require that appropriate “hands on” experience that is necessary in order to properly and effectively function within the respective healthcare environment. The nursing home industry is closely regulated by federal, state and local government.

The consultant/firm will provide employment recruitment services that may include, but not be limited to: placing advertisements in appropriate publications/online, initial screening of all candidates, resume review and screening, eligibility determination, background/reference checking, credential verification, initial interviewing, interview follow up and salary negotiation. Specific recruitment activities will be dependent upon the position and will be determined/dictated by Shaker Place. The job descriptions for which we are seeking employees will be provided to the consultant/firm as the positions are deemed necessary to be filled. Said job descriptions are very defined by task, knowledge required,

certification/licensure and outline the scope/responsibilities that are required by the candidate(s) to fulfill the role of the vacant positions.

The consultant/firm must establish one person who will remain Shaker Place's primary contact during this contract. The primary contact shall have at least five (5) years' experience providing placement services for health care facilities/businesses.

SECTION 5: TERM OF CONTRACT:

- 5.1 The contract period shall be **one (1) year from the date of a fully executed contract.**
- 5.2 At the end of the initial one year contract term upon mutual agreement of the County and the Contractor, the agreement may be renewed for two (2) additional years, in two (2) consecutive one-year intervals. Renewal of multiple item bid awards shall be contingent upon renewal of all items; partial renewals shall not be accepted by the County.
- 5.3 The successful Proposer shall execute a contract with the County of Albany in substantial conformance with this RFP as prepared and approved by the County Attorney.

SECTION 6: COST PROPOSAL:

- 6.1 Submit a cost proposal for the services described above in Section 4, Scope of Services, and on the Cost Proposal Form included herein.
- 6.2 Detail the fee structure for the Proposal. Provide hourly rates and reimbursable costs if not included in the lump sum.
- 6.3 Provide any other relevant information that will assist the County in evaluating your Proposal.

SECTION 7: PROPOSAL SUBMISSIONS

- 7.1 In order for the County to conduct a uniform review process of all proposals, proposals must be submitted in the format set forth below. Failure to follow this format may be cause for rejection of a proposal because adherence to this format is critical for the County's evaluation process:

SECTION I:

Title Page - The title page should reflect the Request for Proposal subject, name of the proposer, address, telephone number and contact person.

Table of Contents - The Table of Contents must indicate the material included in the proposal by section and page number.

SECTION II:

Qualification / Experience - The Qualification / Experience section must address proposer's qualifications and experience to carry out the requested service, inclusive of, but not limited to: qualification to do business in NYS, number of years in business and length of experience.

Resumes - Resumes of professional staff members who will be involved in the County engagement must be included in this section.

SECTION III:

References - The References section must include references from similar type projects.

SECTION IV:

Plan Implementation - The Plan Implementation Section must address the Scope of Services in terms of the proposer's plan to carry out the requested service.

SECTION V:

Cost Proposal Section - The Cost Proposal Section must include all costs associated with the proposer's plan to carry out the requested service. Any cost proposal forms furnished by the County must be included in this section.

SECTION VI:

Mandatory Documentation - The Mandatory Documentation Section must include: The Non-Collusive Bidding Certificate (Attachment "A"), Acknowledgment by Proposer (Attachment "B"), and Vendor Responsibility Questionnaire (Attachment "C"); Iranian Energy Divestment Certification (Attachment "D").

SECTION 8: PROPOSAL EVALUATION

8.1 Proposals will remain valid until the execution of a contract by Albany County, unless otherwise rejected consistent with this RFP.

8.2 Proposals received will be evaluated by a committee with representation from the Albany County **Shaker Place Rehabilitation and Nursing Center**. Proposals shall be evaluated based upon the following:

<i>CRITERIA</i>	<i>WEIGHT</i>
Quality and comprehensiveness of all aspects of the consulting services as it is related to the stated scope of services.	30%
Demonstrated history of providing services for health care providers as stated in the scope of services.	35%
Proposed cost.	25%
Client references.	10%

8.3 Proposals will be examined and evaluated by the **Albany County Shaker Place Rehabilitation and Nursing Center** with the advice of the Albany County Purchasing Agent to determine whether the requirements of this RFP are met and to make a recommendation to the Albany County Executive, the Albany County Contracts Administration Board or the County Legislature for a contract award.

8.4 A notice of contract award shall not be binding upon the County until the contract has been fully executed by both parties

SECTION 9: SECTION NOT IN USE.

SECTION 10: ALTERNATIVES

10.1 Proposer may include in its Proposal items not specified in this RFP, which it would consider pertinent. All such alternatives must be listed separately from the Proposal and the cost thereof must be separate and itemized.

SECTION 11: INDEMNIFICATION

11.1 The successful Proposer shall defend, indemnify and save harmless the County, its employees and agents, from and against all claims, damages, losses and expenses (including without limitations, reasonable attorneys' fees) arising out of, or in consequence of, any negligent or intentional act or omission of the successful Proposer, its employees or agents, to the extent of its or their responsibility for such claims, damages, losses and expenses.

SECTION 12: SPECIFICATION CLARIFICATION

12.1 All inquiries with respect to this Request for Proposals must be directed to the Albany County Purchasing Agent as follows:

Karen A. Storm
Albany County Purchasing Agent
112 State Street, **Room 1000**
Albany, NY 12207
Telephone: (518) 447-7140
Facsimile: (518) 447-5588
Email: Karen.storm@albanycountyny.gov

12.2 All questions about the meaning or intent of the specifications must be submitted to the aforementioned designated person in writing. Replies will be issued by Addenda mailed or delivered to all parties recorded as having received the proposal documents. Questions received less than four (4) days prior to the date of submission of Proposals will not be answered. The County will be bound only by responses given by formal written Addenda.

COUNTY OF ALBANY
RECRUITING CONSULTANT

RFP #2022-034

ADDENDUM #1

March 22, 2022

The following Addendum No. 1 consisting of three (3) pages (including this cover page) is hereby issued on the 22nd day of March, 2022, in connection with the Request for Proposals # 2022-034, Recruiting Consultant for the Shaker Place Rehabilitation and Nursing Center.

COUNTY OF ALBANY

RFP #2022-034

RECRUITING CONSULTANT

ADDENDUM #1

The following information is provided as a result of a question(s) posed by vendor(s):

ITEM #1: The deadline for proposal submission has been extended one week. Proposals are now due by 4:30 PM on Friday, April 1, 2022.

ITEM #2: Please share the list of positions covered under this contract.

RESPONSE #2: As stated in the RFP, we will utilize the Recruiting Consultant for any health care management and hard to fill positions in our operating budget as deemed by facility administration.

ITEM #3: Is there any preferred format for the cost proposal?

RESPONSE #3: The cost proposal should clearly state the comprehensive hourly rate or monthly rate and any/all reimbursable fees/costs not included in the hourly/monthly rate in order to fulfill the Scope of Services stipulated in the RFP.

ITEM #4: Please share the total number of temporary personnel working on the ongoing contract?

RESPONSE #4: There is not currently a contract for this service.

ITEM #5: Please share pay and bill rates of the candidates/resources currently working in the ongoing contract?

RESPONSE #5: Not applicable. Please see Response #4.

ITEM #6: Please share the details of the incumbents/vendors currently providing the recruitment services?

RESPONSE #6: Not applicable. Please see Response #4.

ITEM #7: What are the challenges or pain areas of the ongoing contract?

RESPONSE #7: Not applicable. Please see Response #4.

ITEM #8: How many vendors does the Center plan to award?

RESPONSE #8: One.

ITEM #9: Is there any local preference?

RESPONSE #9: Proposals will be evaluated based on criteria contained in the RFP.

ITEM #10: Is there a tentative budget assigned for the resultant contract?

RESPONSE #10: No.

ITEM #11: What type of work authorization(s) will be considered for the proposed candidates? Is it limited to only U.S. Citizens and Green Card Holders or candidates holding Employment Authorization Document (EAD) will also be considered?

RESPONSE #11: The RFP clearly states requirements of the proposals.

ITEM #12: Can we submit the proposal electronically via e-mail or portal?

RESPONSE #12: No. The RFP clearly states in Section 2: Receipt of Proposals, the requirements/format for the submission of proposals.

ITEM #13: Is this a new initiative? If not, please provide the names of the current vendor(s) providing the services.

RESPONSE #13: Yes. Please see Response #4.

ITEM #14: Can you please let us know the previous spending of this contract?

RESPONSE #14: Not applicable. Please see Response #4.

ITEM #15: Please confirm if we can get the proposals or pricing of the incumbent(s).

RESPONSE #15: Not applicable. Please see Response #4.

ITEM #16: Are there any pain points or issues with the current vendor(s)?

RESPONSE #16: Not applicable. Please see Response #4.

End of Addendum #1

Albany County Request for Contract Approval

Contract #	2022-328
Contract Type	B) CAB Contract
Contract Action	C) Renewal
Contract Action Type	C) Renewal
Department	A7128 - Civic Center
Date Submitted	Tuesday, May 03, 2022
Contact Person	Reilly, David
Contact Phone	1 (518) 447-7034
Vendor Info	Walsh Duffield Companies, Inc. 801 Main Street, Buffalo, NY 14203-1215
Estimated Amount	\$89,470.00
Estimated Term	7/1/2022 to 7/1/2023
Scope of Services	1 year renewal of the Commercial Property Insurance for the TU Center.
Budget Line Item	AA7128 - - - -
Fiscal Impact	County: 100.00% State: 0.00% Federal: 0.00% Local: 0.00% Other: 0.00%
BID, RFP, RFQ Completed?	N/A

Budget Analyst

Date

For Contract Board Use:

Date Approved

Daniel P. McCoy
Albany County Executive

Bruce A. Hidley
Albany County Clerk

Andrew Joyce, Chairman
Albany County Legislature

MVP ARENA

Albany, New York

MEMORANDUM

To: Honorable Members of the CAB Committee
Albany County Executive – Daniel McCoy
Honorable Members of the Albany County Legislature

From: Bob Belber
General Manager – MVP Arena

Date: April 20, 2022

Re: REQUEST FOR APPROVAL - WALSH DUFFIELD COMPANIES, INC.
FOR PROPERTY INSURANCE COVERAGE – FOR MVP ARENA

Walsh Duffield Companies, Inc. for many years has been sourcing and negotiating the very best property insurance that meets all of the requirements established for the many purposes and types of coverage that is needed to properly protect Albany County's interest and ownership in the property and building.

Travelers Insurance Company, which is highly rated with an A.M. Best Company Rating of A++ XV has provided a proposal for July 1, 2022 – July 1, 2023 in the annual amount of \$89,470 and is billed quarterly.

The current policy premium, which is also with Travelers Insurance Company includes an annual premium of \$84,897. Due to market conditions, coming off the pandemic and based on loss ratios there was a small increase in the annual premium for the upcoming year. This increase is less than we had anticipated it might be. I ask the CAB Committee to provide approval for this Insurance Coverage so we can keep the necessary protection and insurance in place starting on July 1, 2022.



Who is Walsh Duffield?

Walsh Duffield Companies, Inc. has been a trusted insurance advisor to individuals and businesses since 1860. This 5th generation family owned business operates with offices in Buffalo, Rochester and Medina. Our organization is made up of 105 associates, across four divisions: Commercial Insurance, Personal Insurance, Group Benefits and Individual Life Insurance. We are an independent agent, which means that we represent many of the leading insurance carriers that enable us to provide our clients with the broadest range of coverage, competitively priced products, along with loss control and claims services tailored to your business.

Our Mission is to create solutions that keep you safe & well.

We do this by providing you with access to group benefits, personal and commercial insurance products from the nation's leading carriers. As a partner, we're here to listen and discover what makes your business unique. We continually strive to provide advice, education and the guidance necessary to manage risk and help you make the best decisions regarding your insurance coverage options.

Our Values

- **Integrity** - Our associates are treated fairly, play by the rules and always operate honestly and ethically.
- **Wellness** - With the support of our leadership, our associates show awareness and strive to take control of all dimensions of their wellness: physical, emotional and financial.
- **Teamwork** - Our associates are expected to take personal responsibility and fully support each other as members of a team.
- **Innovation** - Our associates will always be creative and innovative in pursuit of constant quality improvement.
- **Performance** - Our associates are profit and performance driven based on good data, goals and incentives.

**SMG as Agent for the County of Albany dba
MVP Arena**

Service Team

Individual/Title	Functional Position
Donna J. Bryk, MBA Vice President	Responsible for coordination of all client services E-mail: dbryk@walshduffield.com Phone: 716-362-7393
Elizabeth Miller, ACSR Client Relationship Manager	Responsible for day-to-day service coverage questions, correspondence, billing, etc. E-mail: emiller@walshduffield.com Phone: 716-362-7374
Charmaine Derenda AIC Claims Representative	Contact person for claims reporting/ follow-up with insurance company claims personnel E-mail: cderenda@walshduffield.com Phone: 716-362-7336

Address: 801 Main Street Buffalo, New York 14203 Phone: 716-853-3820 Fax: 716-847-1360 Website: www.walshduffield.com	155 Culver Road, Suite 220 Rochester, New York 14620 585-586-8000 844-847-1360
--	---

7/1/2022 - 7/1/2023

Coverage	2021-2022 Travelers	2022-2023 Travelers
Property NYS Fire Fee	\$84,897.00 \$504.00	\$89,470.00 \$531.00
Rate	2021-2022 Travelers	2022-2023 Travelers
Building	0.052	0.055
Business Personal Property	0.122	0.110
Business Income	0.109	0.086

Exposure Changes

Business Income & Extra Expense:

Limit increased from \$3,873,633 to \$5,294,000

Payment Terms

Direct Billed

Quarterly

This is not a substitute for your insurance policies. Determination and/or application of coverage is totally dependent upon the circumstances surrounding the occurrence and the allegations within the claim and/or lawsuit.

7/1/2022 - 7/1/2023
Commercial Property Coverage

Coverage	2021-2022 Travelers	2022-2023 Travelers
Blanket Real Property & Personal Property	\$126,075,991	\$126,075,991
Loss of Business Income	\$3,873,633	\$5,294,000
Equipment Breakdown	Included	Included
Earth Movement	\$25,000,000	\$25,000,000
Flood	\$25,000,000	\$25,000,000

Coverage: Deluxe Property Coverage Form
 Business Income & Extra Expense
 Rental Value included; Ordinary Payroll Excluded
 Broad Form Flood
 Equipment Breakdown
 Earthquake

Valuation: Replacement Cost
 Co-Insurance not applicable

Additional Covered Property	Limit
Personal Property at Undescribed Premise	\$100,000
At any "exhibition" premises	\$100,000
At any installation premises or temporary storage premises	\$100,000
At any other not owned, leased or regularly operated premises	
Sales Representative Property	\$100,000
Personal Property in Transit	\$100,000

Utility Services	Limit
Combined Direct Damage & Time Element - any one occurrence for	\$1,000,000
Water Supply	
Communication Supply	
Power Supply	
Coverage for Overhead Transmission Lines	Excluded

7/1/2022 - 7/1/2023

Commercial Property Coverage

Included means included in applicable Covered Property Limit of Insurance

Additional Coverages & Coverage Extensions	Limit
Non-Owned Detached Trailers	\$25,000
Ordinance or Law Coverage	\$10,000,000
Outdoor Property - any one tree, shrub, plant	\$100,000
Outside signs	
At all described premises	\$100,000
At all undescribed premises	\$5,000
Personal Effects	\$25,000
Personal Property	
At Premises outside of the coverage territory	\$50,000
In Transit outside of the coverage territory	\$25,000
Pollutant Cleanup & Removal - Annual Aggregate	\$500,000
Preservation of Property	
Expenses to move & temporarily stored property	\$250,000
Direct loss or damage to moved property	Included
Reward Coverage - 25% of covered loss up to a maximum of	\$25,000
Store Water	\$25,000
Theft of Damage to Rented Property	Included
Undamaged Parts of stock in process	\$50,000
Valuable Papers & Records - Cost of Research	
At all described premises	\$50,000
In transit or at all undescribed premises	\$25,000
Water or other substance loss - Tear out & replacement expense	Included
Equipment Breakdown Coverage Extension	Limits
Ammonia Contamination	\$250,000
Hazardous Substance Expenses	\$250,000
Spoilage	\$250,000

Brief Description of Miscellaneous Coverages/Terms

This section is intended to provide a brief highlight of various coverage issues. Please review the forms specifically being offered for details.

Agreed Amount -

Suspends the coinsurance clause eliminating the penalty for under-insurance normally contained in property policies. This endorsement usually requires verification of values through appraisal or recognized valuation methods.

Ordinance or Law -

Undamaged Portion:

Covers loss of value to the undamaged portion of an existing building that an ordinance or law requires to be demolished.

Demolition Cost - Covers the cost to demolish the undamaged portion.

Increased Cost of Construction -

Covers increases in expense to repair or replace the building arising from requirements to bring it up to code or conform in other ways to current laws, such as ADA accessibility requirements.

Business Income / Extra Expense -

Provides money for lost income, should your business suffer a covered loss that prevents you from operating. An extended period of indemnity endorsement will continue to pay loss of income from the time your operations begin again until the specified time period is over. This allows you time to rebuild your clientele to the point you were at before the loss.

Service Interruption Coverage -

Can be on a direct damage basis (covering damage to your property) or on an indirect damage basis (covering your loss of income) which results from damage to properties that provide water, communications or power supply services. A broader form covers damage to overhead power transmission and communication lines. Needs to be considered for property and boiler / machinery perils.

Boiler & Machinery Coverage

Provides coverage for boilers and other machinery used to service the building. The policy can be broadened to include production machinery as well. Coverage is provided for damage due to explosion or breakdown of machinery, however, wear and tear losses are excluded.

Thank you for your business.

*If you are satisfied with our service, please tell others.
If we can improve in some way, please tell us.*

*We appreciate our relationship with
SMG as Agent for the County of Albany dba
MVP Arena*

Discussed With: _____

Company Name: _____

Signature: _____

Date: _____

Albany County Request for Contract Approval

Contract #	2022-322
Contract Type	B) CAB Contract
Contract Action	A) New
Contract Action Type	A) New
Department	D5110 - Maintenance of Roads and Bridges
Date Submitted	Thursday, April 28, 2022
Contact Person	Ramundo, Lisa
Contact Phone	() -518
Vendor Info	Creighton Manning Engineering 2 Winners Circle, Albany, NY 12205
Estimated Amount	\$67,500.00
Estimated Term	6/1/2022 to 6/30/2023
Scope of Services	Design Services for the Rehabilitation of the Krumkill Road Bridge over the Normanskill Creek Project in the Town of New Scotland. The contract period will be for one year (6/1/2022-6/30-2023). This project is 100% County funded using Bond HHT8 (Resolution 93 dated 3/14/2022).
Budget Line Item	DD5110 - 00000 - - -
Fiscal Impact	County: 100.00% State: 0.00% Federal: 0.00% Local: 0.00% Other: 0.00%
BID, RFP, RFQ Completed?	Yes - RFP

Budget Analyst

Date

For Contract Board Use:

Date Approved

Daniel P. McCoy
Albany County Executive

Bruce A. Hidley
Albany County Clerk

Andrew Joyce, Chairman
Albany County Legislature



DANIEL P. McCOY
COUNTY EXECUTIVE

DANIEL C. LYNCH
DEPUTY COUNTY EXECUTIVE

COUNTY OF ALBANY
DEPARTMENT OF PUBLIC WORKS
449 NEW SALEM ROAD
VOORHEESVILLE, NEW YORK 12186-4826
(518) 765-2055 - FAX (518)447-7047
WWW.ALBANYCOUNTY.COM

LISA M. RAMUNDO
COMMISSIONER

SCOTT D. DUNCAN
DEPUTY COMMISSIONER

MEMORANDUM

To: Hon. Daniel P. McCoy, County Executive
Hon. Andrew Joyce, Chairman of the Legislature
Hon. Bruce Hidley, County Clerk

From: Lisa M. Ramundo, Commissioner

Date: April 28, 2022

Re: Contract Request

Dear Contract Administration Board:

The Department of Public Works is requesting approval to enter into a contract with Creighton Manning Engineering for the Design Services for the Rehabilitation of the Krumkill Road Bridge over the Normanskill Creek Project in the Town of New Scotland. The Contract is in the amount of \$67,500.00 and will be for a one year period (6/1/2022-6/30/2023).

The County Purchasing Agent received four (4) proposals for this project. Our engineering staff reviewed and rated the proposals and recommended the award of this contract to Creighton Manning Engineering based on best project approach. This project is 100% County funded using the 2022 Bond.

If there are any questions or further information is needed, please feel free to contact my office.



DANIEL P. McCOY
COUNTY EXECUTIVE

COUNTY OF ALBANY
DEPARTMENT OF GENERAL SERVICES
PURCHASING DIVISION
112 STATE STREET, ROOM 1000
ALBANY, NEW YORK 12207-2021
(518) 447-7140 - FAX (518) 447-5588

DAVID M. LATINA
COMMISSIONER OF GENERAL SERVICES

KAREN A. STORM
PURCHASING AGENT

MEMORANDUM

TO: Lisa M. Ramundo, Commissioner
Public Works

FROM: Karen Storm *Karen*
Purchasing Agent

DATE: April 27, 2022

RE: RFP#2022-006
Design & Construction Inspection Services
Krumkill Rd Bridge over the Normanskill Bridge Rehabilitation Project

I am in receipt of your recommendation to award the aforementioned Request for Proposals to Creighton Manning Engineering in the amount not to exceed \$67,500.00

I have reviewed your scoring sheets and believe that you have performed a thorough evaluation of the proposal(s) submitted. I have no objection to the selection of Creighton Manning Engineering for an award.

Please obtain the necessary contract approval of the Contract Administration Board, so that we may issue a Notice of Award to the successful proposer.



DANIEL P. McCOY
COUNTY EXECUTIVE

COUNTY OF ALBANY
DEPARTMENT OF PUBLIC WORKS
449 NEW SALEM ROAD
VOORHEESVILLE, NEW YORK 12186-4826
(518) 765-2055 - FAX (518) 447-7047
WWW.ALBANYCOUNTY.COM

LISA M. RAMUNDO
COMMISSIONER

RECOMMENDATION NOTICE

TO: Karen Storm, Purchasing Agent

FROM: Lisa M. Ramundo, Commissioner

DATE: April 26, 2022

RE: RFP #2022-006
Design Services
Krumkill Road Bridge over the Normanskill Bridge
Rehabilitation Project

Upon review and rating of the four (4) Proposals that were received regarding the aforementioned project, I would like to recommend Creighton Manning Engineering for the award of this proposal for a contract amount not to exceed \$67,500.00.

I have attached a copy of our Engineering Divisions recommendation along with the Rating and Evaluation Sheets.

If you have any questions, please feel free to contact my office.

LMR:ct



DANIEL P. McCOY
COUNTY EXECUTIVE

COUNTY OF ALBANY
DEPARTMENT OF PUBLIC WORKS
449 NEW SALEM ROAD
VOORHEESVILLE, NEW YORK 12186-4826
(518) 765-2055 - FAX (518) 447-7047
WWW.ALBANYCOUNTY.COM

LISA M. RAMUNDO
COMMISSIONER

Memorandum

TO: Lisa M. Ramundo, Commissioner

FROM: Bill Anslow, Civil Engineer

DATE: April 26, 2022

RE: RFP#2022-006
Design Services
Krumkill Rd Bridge over the Normanskill Bridge Rehabilitation Project

Attached please find the Rating Sheet along with Evaluation Score Sheets for the subject project. After reviewing all four (4) of the RFP's, we recommend the project be awarded to Creighton Manning Engineering (CME) based on the best understanding of the scope of the project. CME's proposal provides the best value for the County for this project. Total contract amount not to exceed is \$67,500.00.

Please let me know if you have any questions.

WA:ct

BID TALLY SHEET
RFP 2022-006

Design and CI for
Krumkill Rd Bridge over Normanskill Bridge Rehabilitation Project

<u>COMPANY</u>	<u>Design</u>	<u>CI</u>	<u>Contingency</u>	<u>Testing</u>	<u>PROPOSED PRICE</u>
GPI	\$ 45,000	\$ 82,000	\$ 6,350	\$ 15,000	\$ 148,350
Barton & Loguidice	\$ 71,290	\$ 75,000	\$ 7,300	\$ 15,000	\$ 168,590
MJ Engineering	\$ 54,695	\$ 83,400	\$ 6,905	\$ 15,000	\$ 160,000
Creighton Manning	\$ 60,000	\$ 90,000	\$ 7,500	\$ 15,000	\$ 172,500

RATING SHEET
RFP 2022-006
Design and CI for

Krumkill Rd Bridge over Normanskill Bridge Rehabilitation Project

	BARTON & LOGUIDICE	CME	GPI	MJ ENGINEERING & LAND SURVEYING
Lisa	9.225	9.500	9.500	9.550
Bill	7.950	8.400	8.700	8.200
Brent	8.150	8.900	8.450	8.800
Totals	25.325	26.800	26.650	26.550
Average	8.442	8.933	8.883	8.850
Rank	4	1	2	3

RFP 2022-006 Design and CI for Krumkill Rd Bridge over Normanskill Bridge Rehabilitation Project

Proposal Rating Worksheet

Proposer: Barton and Loguidice

	Weight	Brent		Lisa		Bill	
		Rate	Score	Rate	Score	Rate	Score
Proposer's Comprehension of Required (work) Scope of Services	25%	9	2.25	8.5	2.125	9	2.25
Prior Experience in Similar Projects	20%	8	1.6	10	2	8	1.6
Ability to Keep Project on Schedule and Within Budget (Include Examples and a proposed project schedule)	20%	7	1.4	10	2	5	1
Total Proposed Price	20%	8	1.6	8	1.6	8	1.6
Client References	5%	10	0.5	10	0.5	10	0.5
Proposed Project Staffing (Evaluation of Employees' Resumes)	10%	8	0.8	10	1	10	1
TOTALS:			8.15		9.225		7.95

[Handwritten signature]

[Handwritten signature]

NOTES:

RFP 2022-006 Design and CI for Krumkill Rd Bridge over Normanskill Bridge Rehabilitation Project

Proposal Rating Worksheet

Proposer: Creighton Manning

	Weight	Brent		Lisa		Bill	
		Rate	Score	Rate	Score	Rate	Score
Proposers Comprehension of Required (work) Scope of Services	25%	10	2.5	10	2.5	10	2.5
Prior Experience in Similar Projects	20%	10	2	10	2	9.5	1.9
Ability to Keep Project on Schedule and Within Budget (Include Examples and a proposed project schedule)	20%	7.5	1.5	10	2	5	1
Total Proposed Price	20%	7.5	1.5	7.5	1.5	7.5	1.5
Client References	5%	10	0.5	10	0.5	10	0.5
Proposed Project Staffing (Evaluation of Employees' Resumes)	10%	9	0.9	10	1	10	1
TOTALS:			8.9		9.5		8.4

NOTES:

RFP 2022-006 Design and CI for Krumkill Rd Bridge over Normanskill Bridge Rehabilitation Project

Proposal Rating Worksheet

Proposer: GPI

	Weight	Brent		Lisa		Bill	
		Rate	Score	Rate	Score	Rate	Score
Proposers Comprehension of Required (work) Scope of Services	25%	7	1.75	8	2	8	2
Prior Experience in Similar Projects	20%	10	2	10	2	8	1.6
Ability to Keep Project on Schedule and Within Budget (Include Examples and a proposed project schedule)	20%	6	1.2	10	2	8	1.6
Total Proposed Price	20%	10	2	10	2	10	2
Client References	5%	10	0.5	10	0.5	10	0.5
Proposed Project Staffing (Evaluation of Employees' Resumes)	10%	10	1	10	1	10	1
TOTALS:			8.45		9.5		8.7

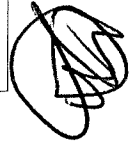
NOTES:

RFP 2022-006 Design and CI for Krumkill Rd Bridge over Normanskill Bridge Rehabilitation Project

Proposal Rating Worksheet

Proposer: MJ Engineering

	Weight	Brent		Lisa		Bill	
		Rate	Score	Rate	Score	Rate	Score
Proposers Comprehension of Required (work) Scope of Services	25%	8	2	9	2.25	8	2
Prior Experience in Similar Projects	20%	9	1.8	10	2	7.5	1.5
Ability to Keep Project on Schedule and Within Budget (Include Examples and a proposed project schedule)	20%	9	1.8	10	2	7	1.4
Total Proposed Price	20%	9	1.8	9	1.8	9	1.8
Client References	5%	10	0.5	10	0.5	10	0.5
Proposed Project Staffing (Evaluation of Employees' Resumes)	10%	9	0.9	10	1	10	1
TOTALS:			8.8		9.55		8.2

NOTES:

**NOTICE TO PROPOSERS -- ALBANY COUNTY
REQUEST FOR PROPOSALS #2022-006**

Sealed Proposals for **Design and Construction Inspection Services for Krumkill Road Bridge over the Normanskill (BIN 3301270) Bridge Rehabilitation Project** as requested by Albany County Department of Public Works will be received by the Albany County Purchasing Agent, Room 1000, 112 State Street, Albany, New York 12207 until 4:30 PM, local time on Friday, April 1, 2022.

Request for Proposal (RFP) documents may be obtained at the office of the Albany County Purchasing Agent, as noted above. RFP documents may be available for download from the Empire State Bid System website at <http://www.empirestatebidsystem.com>, starting by close of business (4:30 p.m.) on March 17, 2022

Karen A. Storm
Purchasing Agent

Dated: March 4, 2022
Albany, New York

PUBLISH ONE DAY – MARCH 17, 2022-- THE EVANGELIST
PUBLISH ONE DAY – MARCH 17, 2022 -- THE TIMES UNION

Albany County Request for Contract Approval

Contract #	2022-263
Contract Type	B) CAB Contract
Contract Action	A) New
Contract Action Type	A) New
Department	G8130 - Sewage Treatment
Date Submitted	Tuesday, April 12, 2022
Contact Person	Gaudio, Angelo
Contact Phone	() -518
Vendor Info	Gammie Air Monitoring LLC 16 Progress Circle, Suite 1B, Newington, CT 06111
Estimated Amount	\$32,400.00
Estimated Term	5/1/2022 to 12/31/2022
Scope of Services	Provide annual air compliance testing for the North and South Plant sewage sludge incinerators
Budget Line Item	GG8130 - 44108 - - -
Fiscal Impact	County: 100.00% State: 0.00% Federal: 0.00% Local: 0.00% Other: 0.00%
BID, RFP, RFQ Completed?	Yes - RFP

Budget Analyst

Date

For Contract Board Use:

Date Approved

Daniel P. McCoy
Albany County Executive

Bruce A. Hidley
Albany County Clerk

Andrew Joyce, Chairman
Albany County Legislature



DANIEL P. MC COY
COUNTY EXECUTIVE

COUNTY OF ALBANY
WATER PURIFICATION DISTRICT
1 CANAL ROAD SOUTH
ALBANY, NEW YORK 12204
REMITTANCE: 112 STATE ST., BASEMENT, ALBANY, NY 12207
PHONE: (518) 447-1611 FAX: (518) 433-0369
www.albanycounty.com

COMMISSION
JOHN R. ADAIR, JR.
CHAIRMAN
JOHN W. BISHOP, JR.
NICHOLAS W. FOGLIA
DENNIS RIGOSU
SEAN WARD

ANGELO GAUDIO, P.E.
EXECUTIVE DIRECTOR

April 12, 2022

Hon. Daniel P. McCoy
County Executive
112 State Street
Albany, NY 12207

Hon. Andrew Joyce
Chairman
Albany County Legislature
112 State Street – Suite 710
Albany, NY 12207

Hon. Bruce Hidley
County Clerk
112 State Street
Albany, NY 12207

Re: RFB-2022-036-Incinerator Air Compliance Testing

Dear Messrs. McCoy, Joyce, Hidley:

The Water Purification District (District) is requesting authorization to award the above subject contract to Gammie Air Monitoring for a total not to exceed amount of \$32,400.00 for a contract term of 8 months which is scheduled to run from May 1, 2022 through December 31, 2022. Work shall include permit required air testing of both the North and South Plant incinerators.

Two bids were received and Gammie Air Monitoring was the lowest responsible bidder. The bid tabulation, District's recommendation memo and Purchasing Division's concurrence memo are attached herein.

Should you have any questions please feel free to contact me at 518-447-1617.

Sincerely,

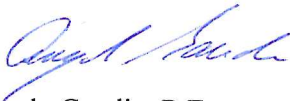
A handwritten signature in blue ink, appearing to read "Angelo Gaudio".

Angelo Gaudio, P.E.
Executive Director

Enc: District Recommendation Memo
Bid Tabulation & Scoring Sheet
Purchasing Division Concurrence Memo

Cc: Lucas Rogers, Policy Analyst
Christopher Herbert, Budget Analyst



DANIEL P. McCOY
COUNTY EXECUTIVE

COUNTY OF ALBANY
DEPARTMENT OF GENERAL SERVICES
PURCHASING DIVISION
112 STATE STREET, ROOM 1000
ALBANY, NEW YORK 12207-2021
(518) 447-7140 - FAX (518) 447-5588

DAVID M. LATINA
COMMISSIONER OF GENERAL SERVICES

KAREN A. STORM
PURCHASING AGENT

MEMORANDUM

TO: Angelo Gaudio, Executive Director
Water Purification District

FROM: Karen Storm *Karen*
Purchasing Agent

DATE: April 8, 2022

RE: RFP#2022-036

I am in receipt of your recommendation to award the aforementioned to Gammie Air Monitoring for a contract cost not to exceed \$32,400.00.

I have reviewed your scoring sheets and believe that you have performed a thorough evaluation of the proposal (s) submitted. I have no objection to the selection of Gammie Air Monitoring.

Please obtain the necessary contract approval of the Contracts Administration Board, so that we may issue a Notice of Award to the successful proposer.



DANIEL P. MCCOY
COUNTY EXECUTIVE

COUNTY OF ALBANY
WATER PURIFICATION DISTRICT
1 CANAL ROAD, SOUTH
ALBANY, NEW YORK 12204
REMITTANCE: 112 STATE ST., BASEMENT, ALBANY, NY 12207
PHONE: (518) 447-1611 FAX: (518) 433-0369
www.albanycounty.com

COMMISSION
DENNIS RIGOSU
CHAIRMAN

JOHN W. BISHOP, JR.
NICHOLAS W. FOGLIA
MAGGIE ALIX

ANGELO S. GAUDIO, P.E.
EXECUTIVE DIRECTOR

MEMORANDUM

To: Karen Storm, Purchasing Agent
From: Angelo Gaudio, Executive Director 
Subject: RFP-2022-036 Air Compliance Testing Multiple Hearth Incinerators
Date: April 8, 2022

The Water Purification District recommends award of the above referenced RFP to Gammie Air Monitoring for a total not to exceed price of \$32,400.00. Gammie Air Monitoring proposed the lowest total base cost and has a strong comprehension of the required work involved due to their prior experience in performing the testing on the Water Purification incinerator stacks.

I have enclosed the review committee scoring. If you have any questions, please contact me. Thank you for all your assistance.

If you have any questions, please feel free to contact me at 447-1617.

Enc.

RFP #2022-036: Air Compliance Testing

Proposal Rating Worksheet

Summary

	Weight	Gammie Air Monitoring		Empire Stack Testing	
		Rate	Score	Rate	Score
Proposers comprehension of the required work, including approach as outlined in Section 4 Scope of Services	30%	10	3	10	3
professional qualification and prior experience in similar projects including designated project team	25%	10	2.5	9	2.25
Total Proposed Price					
	20%	10	2	8	1.6
Proposers demonstrated capabilities (Including equipment financial solvency and company location	10%	10	1	10	1
Client References	5%	9	0.45	9	0.45
Staffing (Evaluation of proposed team resumes)	10%	10	1	9	0.9
TOTALS:				9.95	9.2

NOTES:

Albany County Request for Contract Approval

Contract #	2022-307
Contract Type	B) CAB Contract
Contract Action	A) New
Contract Action Type	A) New
Department	G8130 - Sewage Treatment
Date Submitted	Tuesday, April 26, 2022
Contact Person	Gaudio, Angelo
Contact Phone	() -518
Vendor Info	Empire Forklift Inc. PO Box 108, Bloomingburg, NY 12721
Estimated Amount	\$28,225.00
Estimated Term	5/9/2022 to 7/26/2022
Scope of Services	Purchase and delivery of a 2022 Clark GTS25 Pneumatic Tire Forklift.
Budget Line Item	GG8130 - 22400 - - -
Fiscal Impact	County: 100.00% State: 0.00% Federal: 0.00% Local: 0.00% Other: 0.00%
BID, RFP, RFQ Completed?	Yes - BID

Budget Analyst

Date

For Contract Board Use:

Date Approved

Daniel P. McCoy
Albany County Executive

Bruce A. Hidley
Albany County Clerk

Andrew Joyce, Chairman
Albany County Legislature



DANIEL P. MCCOY
COUNTY EXECUTIVE

COUNTY OF ALBANY
WATER PURIFICATION DISTRICT
1 CANAL ROAD, SOUTH
ALBANY, NEW YORK 12204

REMITTANCE: 112 STATE ST., BASEMENT, ALBANY, NY 12207
PHONE: (518) 447-1611 FAX: (518) 433-0369
www.albanycounty.com

COMMISSION
DENNIS RIGOSU
CHAIRMAN

JOHN W. BISHOP, JR.
NICHOLAS W. FOGLIA
MAGGIE ALIX

April 25, 2022

ANGELO GAUDIO, P.E.
EXECUTIVE DIRECTOR

Hon. Daniel P. McCoy
County Executive
112 State Street
Albany, NY 12207

Hon. Andrew Joyce
Chairman
Albany County Legislature
112 State Street – Suite 710
Albany, NY 12207

Hon. Bruce Hidley
County Clerk
112 State Street
Albany, NY 12207

**Re: RFB-2022-047 - Pneumatic Tire Forklift
Empire Forklift Inc**

Dear Messrs. McCoy, Joyce, Hidley:

The Water Purification District is requesting authorization to purchase a 2022 Clark GTSS25 pneumatic tire forklift from Empire Forklift Inc. for \$28,225. Five bids were received and Empire Forklift Inc., was the lowest responsible bidder for the above referenced bid. A copy of the bid results, the District's award recommendation memo and the Purchasing Department's concurrence memo to award the contract to Empire Forklift Inc., is attached for your reference.

If you have any questions or concerns you may reach me at (518) 447-1617.

Sincerely,

Angelo Gaudio, P.E.
Executive Director

Enc.: Bid Results
District Recommendation Memo
Purchasing Dept. Memo

RFB-2022-047 Tabulation
Pneumatic Tire Forklift

Bidder	Thompson & Johnson Equipment	Empire Forklift	Octane Forklifts	Alta Enterprises	Technology International
Delivered Price	\$ 29,150.00	\$ 28,225.00	\$ 32,969.00	\$ 40,316.10	\$ 35,250.00
Spec Sheet Included	Clark GTS25	ClarkGTS25	2022 Octane FY25	Hyster H50XT	Hyundai 25-9A

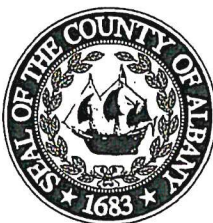

DANIEL P. MCCOY
COUNTY EXECUTIVE

COUNTY OF ALBANY
WATER PURIFICATION DISTRICT
1 CANAL ROAD, SOUTH
ALBANY, NEW YORK 12204

REMITTANCE: 112 STATE ST., BASEMENT, ALBANY, NY 12207
PHONE: (518) 447-1611 FAX: (518) 433-0369
www.albanycounty.com

COMMISSION

DENNIS RIGOSU
CHAIRMAN

MAGGIE A. ALIX
JOHN W. BISHOP, JR.
NICHOLAS W. FOGLIA

ANGELOS. GAUDIO, P.E.
EXECUTIVE DIRECTOR

MEMORANDUM

To: Karen Storm, Purchasing Agent
From: Angelo Gaudio, Executive Director 
Subject: RFB-2022.047-Pneumatic Tire Forklift
Date: April 25, 2022

The Water Purification District recommends award of RFB-2022-047, pneumatic tire forklift to Empire Forklift Inc., for \$28,225.00. Empire Forklift Inc., was the lowest responsible bidder of the five bids received.

If you have any questions, please feel free to contact me at 447-1617 _



DANIEL P. McCOY
COUNTY EXECUTIVE

COUNTY OF ALBANY
DEPARTMENT OF GENERAL SERVICES
PURCHASING DIVISION
112 STATE STREET, ROOM 1000
ALBANY, NEW YORK 12207-2021
(518) 447-7140 - FAX (518) 447-5588

DAVID M. LATINA
COMMISSIONER OF GENERAL SERVICES

KAREN A. STORM
PURCHASING AGENT

MEMORANDUM

TO: Angelo Gaudio, Executive Director
Water Purification District

FROM: Karen Storm *Karen Storm*
Purchasing Agent

DATE: April 25, 2022

RE: RFQ #2022-047

I am in receipt of your recommendation to award the aforementioned to Empire Forklift, Inc. in the amount of \$28,225.00.

As Empire Forklift, Inc. is the lowest responsible and responsive bidder, I concur with your recommendation.

Please obtain the necessary contract approval of the Contract Administration Board, so that we may issue a Notice of Award.

Albany County Request for Contract Approval

Contract #	2022-308
Contract Type	B) CAB Contract
Contract Action	A) New
Contract Action Type	A) New
Department	G8130 - Sewage Treatment
Date Submitted	Tuesday, April 26, 2022
Contact Person	Gaudio, Angelo
Contact Phone	() -518
Vendor Info	EnviroCare International 507 Green Island Rd, American Canyon, CA 94503
Estimated Amount	\$35,870.00
Estimated Term	5/9/2022 to 5/26/2022
Scope of Services	Purchase and delivery of a replacement quench section for Venturi Scrubber at North Plant. Existing scrubber is manufactured by EnvirCare.
Budget Line Item	GG8130 - 44070 - - -
Fiscal Impact	County: 100.00% State: 0.00% Federal: 0.00% Local: 0.00% Other: 0.00%
BID, RFP, RFQ Completed?	N/A

Budget Analyst

Date

For Contract Board Use:

Date Approved

Daniel P. McCoy
Albany County Executive

Bruce A. Hidley
Albany County Clerk

Andrew Joyce, Chairman
Albany County Legislature



DANIEL P. MCCOY
COUNTY EXECUTIVE

COUNTY OF ALBANY
WATER PURIFICATION DISTRICT
1 CANAL ROAD, SOUTH
ALBANY, NEW YORK 12204
REMITTANCE: 112 STATE ST., BASEMENT, ALBANY, NY 12207
PHONE: (518) 447-1611 FAX: (518) 433-0369
www.albanycounty.com

COMMISSION
DENNIS RIGOSU
CHAIRMAN

JOHN W. BISHOP, JR.
NICHOLAS W. FOGLIA
MAGGIE ALIX

April 25, 2022

ANGELO GAUDIO, P.E.
EXECUTIVE DIRECTOR

Hon. Daniel P. McCoy
County Executive
112 State Street
Albany, NY 12207

Hon. Andrew Joyce
Chairman
Albany County Legislature
112 State Street – Suite 710
Albany, NY 12207

Hon. Bruce Hidley
County Clerk
112 State Street
Albany, NY 12207

**Re: EnviroCare International
North Plant Venturi Scrubber Quench Section Replacement**

Dear Messrs. McCoy, Joyce, Hidley:

The Water Purification District is requesting authorization to purchase a replacement quench section for the venturi scrubber at the North Plant from EnviroCare International (EnviroCare) in the amount of \$ 35,870.00. The existing scrubber is manufactured by EnviroCare and the replacement quench section is a direct OEM replacement part and propriety to EnviroCare. The quote from EnviroCare and associated sole source letter is attached for your reference.

The venturi scrubber is the system that treats or scrubs the sewage sludge incinerator gas emissions before they are discharged to the atmosphere. The quench section is an important component as it cools the incinerator gases to an acceptable level before the gases can be treated by subsequent scrubber sections.

If you have any questions or concerns you may reach me at (518) 447-1617.

Sincerely,

A handwritten signature in blue ink, appearing to read "Angelo Gaudio".

Angelo Gaudio, P.E.
Executive Director

Enc.: EnviroCare Quote
Sole Source Letter

County of Albany
Department of General Services – Purchasing Division
Sole Source Justification

Procurement Policy, Section IV: Sole Source Procurements

A sole source procurement is justified when there is only one good or service that can reasonably meet the need and there is only one vendor who can provide the good or service.

Department: Water Purification District

Contact Name: Angelo Gaudio

Phone #: 518-477-1617

Requisition #: _____

Describe in detail the products and/or services to be procured:

Replacement of OEM quench section parts associated with North Plant venturi Scrubber

Detail how this/ these produce(s) meet(s) your needs. Define the unique benefits to the County of the item as compared to other products in the marketplace. Show that no other product provides substantially equivalent or similar benefits and that, considering the benefits received, the cost of the item is reasonable in comparison to other products in the marketplace. (Attach a separate page if needed)

EnviroCare International is the manufacturer of the venturi scrubber which is utilized at the District's North and South Plant. The scrubber is proprietary and the replacement parts requested are OEM parts and compatible with the existing scrubber system.

Vendor Name: EnviroCare International

Vendor Address: 507 Green Island Road
American Canyon, CA 94503

Phone: 707-638-6800

Fax: 707-638-6898

Product Needed by date: ASAP

Estimated Total Dollars for this procurement: \$ 35,870

County of Albany
Department of General Services – Purchasing Division
Sole Source Justification

Attach a detailed explanation of Vendor Sole Source Status, i.e., what is the basis for your identifying this vendor as a sole source? Check any that apply.

- The vendor is the manufacturer of the product and has no distributors.
(Attach manufacturer's letter as documentation.)
- The vendor is the only reseller of the manufacturer's product in this geographic region.
(Attach manufacturer's letter as documentation.)
- Item to be purchased is a supply for equipment which is under warranty,
and use of any product other than specified will void the warranty.
(Attach copy of warranty with such requirement highlighted).
- Item is proprietary and is additional product or software which must work
with an existing system.
(Provide letter of documentation from system manufacturer.)
- Product has been standardized for use in Albany County through the
Albany County legislative process.
(Attach copy of Resolution.)
- Other
(Provide a statement on a separate page with detailed documentation.)

Department Head or Designee:

Angelo Gaudio

Signature:

Angelo Gaudio

SPARE PARTS QUOTATION

EnviroCare International
The Leader in Pollution Control Equipment

ENVIROCARE JOB #6108
 DATE QUOTED: 4.15.22

**ALBANY COUNTY SEWER SERVICES
 ALBANY, NY**

PART NUMBER	QUANTITY REQUESTED	QUANTITY INSTALLED	SIZE	PART DESCRIPTION	UNIT PRICE (USD)	TOTAL PRICE (USD)	DELIVERY TIME
6108.500-1M	1			MODIFIED QUENCH FOR NORTH UNIT(S) INCLUDING: QUENCH INLET FLANGE/ SEAL RING 310 SS, 46"Ø x 3/16" UPPER SECTION W/ LANCE PORTS 316 SS, 46"Ø X 32"Ø NECKDOWN 316 SS, 32"Ø X 3/16" 316 SS THROAT W/ 3" X 3" FLANGE, EXTENDED 15" DEEP WEIR W/ 12" TRAP HEIGHT	\$ 29,870.00	\$ 29,870.00	16 WEEKS AFTER APPROVED DRAWING(S)
	1			FREIGHT TO SITE	\$ 6,000.00	\$ 6,000.00	
Total Cost:						\$ 35,870.00	

**Note: The above noted pricing is Exworks (EXW) Point of Manufacture and valid for 30 days from the date quote. Shipping is not included in above price. Payment terms are net 30 days.*

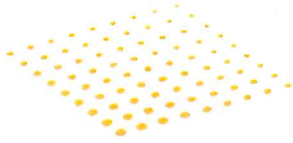

EnviroCare International

507 Green Island Road
American Canyon, CA 94503 USA

Tel. 707.638.6800
Fax. 707.638.6898

April 20, 2022

Albany County Water Purification District
112 State Street, Basement
Albany, New York 12207

Re: EnviroCare VenturiPak Scrubber Replacement Parts

Attn: Tyler Masick,

EnviroCare International, Inc is the Original Equipment Manufacturer (OEM) of the installed VenturiPak Scrubber System at the Albany County Water Purification District North and South Plants. All of the scrubber components are part of a proprietary wet scrubber design in which there are no authorized distributors. Spare parts for the wet scrubber system are purchased directly from EnviroCare International, Inc.

Please do not hesitate to contact us with any questions.

Best regards,

Robert A. Yates
EnviroCare International, Inc.

NOZZLE SCHEDULE							SERVICE DESCRIPTION
NO.	QTY	SIZE	TYPE	RATING	SCH.	MATL.	
A	1	4"	-	-	-	316L-SS	PROCESS GAS INLET
B	1	3"	-	-	-	316L-SS	PROCESS GAS OUTLET
C1-C3	3	6"	RFW	150#	10	316L-SS	QUENCH INLET FLANGE
D1-D2	2	2"	RFW	150#	40	316L-SS	QUENCH SPRAY LANCE

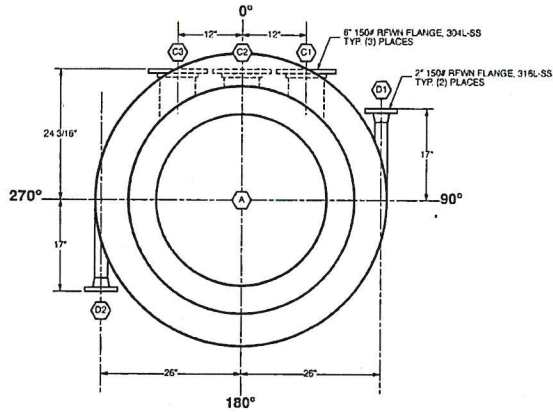

PLAN VIEW

ORIENTATIONS ONLY FOR ELEVATIONS SEE ELEVATION VIEW
INLET FLANGE ASSEMBLY NOT SHOWN FOR CLARITY

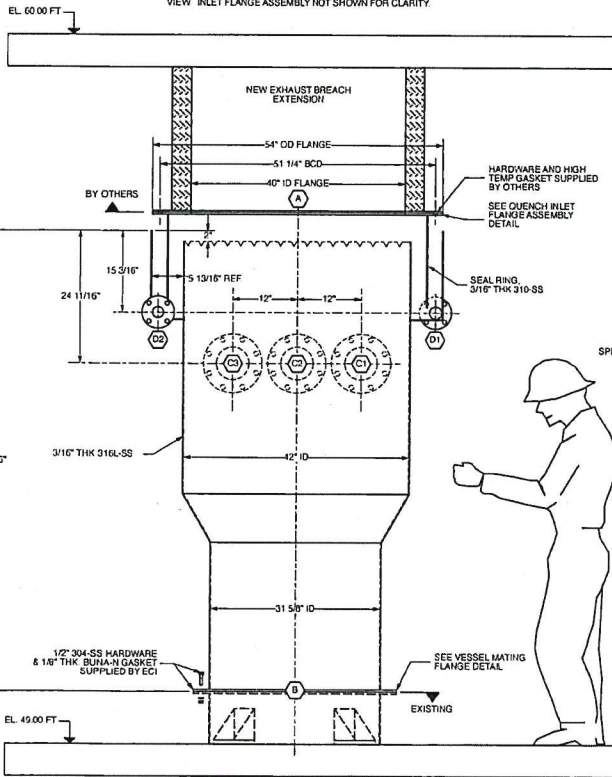

ELEVATION VIEW

ELEVATIONS ONLY FOR ORIENTATIONS SEE PLAN VIEW

IMPORTANT!!
CLIENT TO VERIFY EXHAUST BREACH FLANGE DIMENSIONS
BREACH FLANGE MUST MATCH QUENCH INLET FLANGE
DIMENSIONS AS SHOWN ON THIS DRAWING.

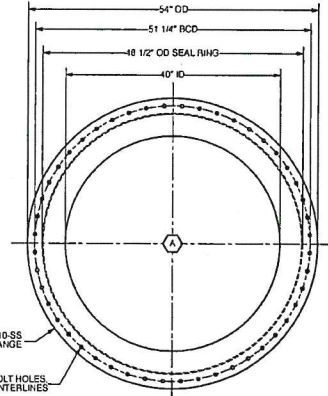

QUENCH INLET FLANGE ASSEMBLY

EXHAUST BREACH FLANGE TO MATCH THE QUENCH INLET FLANGE DIMENSIONS
HARDWARE AND GASKET SUPPLIED AND INSTALLED BY OTHERS

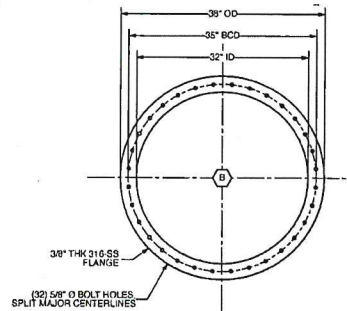

VESSEL MATING FLANGE

HARDWARE AND GASKET SUPPLIED BY ENVIRO-CARE

ALBANY COUNTY SEWER DISTRICT PO. XYZ DATED ABC

U.S. PATENT NO.: 6,719,829
U.S. PATENT NO.: 5,799,233
U.S. PATENT NO.: 5,279,846
OTHER U.S. PATENTS PENDING

- NOTES:**
- ONE (1) QUENCH VESSEL SUPPLIED BY ENVIRO-CARE AND INSTALLED BY OTHERS.
 - ALL SHELL MATERIAL TO BE 3/16" THK 316L-SS UNLESS OTHERWISE NOTED. VESSEL FINISH TO BE SANDBLASTED TO SSPC-SP-6.
 - QUENCH INLET FLANGE ASSEMBLY FURNISHED LOOSE BY ENVIRO-CARE AND INSTALLED BY OTHERS. QUENCH INLET GASKET AND HARDWARE SUPPLIED AND INSTALLED BY OTHERS.
 - DIMENSION TOLERANCE TO BE +/- .18".
 - SUPPORT STRUCTURES AND ACCESS STRUCTURES ARE SUPPLIED AND INSTALLED BY OTHERS.
 - DRY LOAD IS ~1,000LBS.

DOCUMENT RELEASE

Preliminary Issues
 Certified for Construction
 For Customer Use
 As Built

BY: *RJA* DATE: 4/15/22

NO.	REVISION DESCRIPTION	BY	APP	DATE

EnviroCare International
507 Green Island Road, American Canyon, CA 94503
Tel: 707/630-6500 Fax: 707/630-6596

MODIFIED NORTH UNIT QUENCH SPOOL
MicroMist™ VENTURI SCRUBBER

DATE	DESCRIPTION	BY	APP	DATE
DEC 04.11.17				
DEC 04.11.17				
MAY 04.13.17				
MAY 04.13.17				

ALBANY COUNTY SEWER DISTRICT
NORTH UNITS UPPER QUENCH REPLACEMENT - ALBANY, NY

6108

C220SP-6108

Confidentiality: All documents, plans, drawings, specifications, and information presented herein shall remain legal property of EnviroCare International, and shall not be copied or communicated to others, without written consent of EnviroCare International, and shall be returned immediately upon request. All Rights Reserved.

Albany County Request for Contract Approval

Contract #	2022-313
Contract Type	B) CAB Contract
Contract Action	A) New
Contract Action Type	A) New
Department	A1680 - Information Services
Date Submitted	Tuesday, April 26, 2022
Contact Person	Blanchard, Perry
Contact Phone	(518) 447-4962
Vendor Info	KnowBe4 33 N Garden Ave, Suite 1200, Clearwater, Florida 33755
Estimated Amount	\$29,317.32
Estimated Term	6/29/2022 to 6/28/2023
Scope of Services	Security Awareness Training Subscription Diamond
Budget Line Item	AA1680 - 44039 AA1432 - 44039 - -
Fiscal Impact	County: 100.00% State: 0.00% Federal: 0.00% Local: 0.00% Other: 0.00%
BID, RFP, RFQ Completed?	N/A

Budget Analyst

Date

For Contract Board Use:

Date Approved

Daniel P. McCoy
Albany County Executive

Bruce A. Hidley
Albany County Clerk

Andrew Joyce, Chairman
Albany County Legislature



DANIEL P. MCCOY
COUNTY EXECUTIVE

M. DAVID REILLY
COMMISSIONER

PATRICK ALDERSON
DEPUTY COMMISSIONER

COUNTY OF ALBANY
DEPARTMENT OF MANAGEMENT AND BUDGET
DIVISION OF INFORMATION SERVICES
112 STATE STREET, ROOM 500
ALBANY, NEW YORK 12207
PHONE: (518) 447-7277 FAX: (518) 447-3000
www.albanycounty.com

PERRY J. BLANCHARD
CHIEF INFORMATION OFFICER

May 2nd, 2022

Honorable Daniel P. McCoy
Albany County Executive
112 State Street, 12th Floor
Albany, NY 12207

Honorable Andrew Joyce, Chairman
Albany County Legislature
112 State Street, 7th Floor
Albany, NY 12207

Honorable Bruce Hidley
Albany County Clerk
Albany County Courthouse
15 Eagle Street, 1st Floor
Albany, NY 12207

Dear Mr. McCoy, Mr. Joyce and Mr. Hidley,

The Albany County Division of Information Services requests the approval to contract with KnowBe4 for Security Awareness Training purposes. The subscription dates would be June 29th, 2022 through June 28th, 2023. If you have any questions or concerns, please feel free to give me a call.

Thank you,
Perry Blanchard



DANIEL P. MCCOY
COUNTY EXECUTIVE

M. DAVID REILLY
COMMISSIONER

PATRICK ALDERSON
DEPUTY COMMISSIONER

COUNTY OF ALBANY
DEPARTMENT OF MANAGEMENT AND BUDGET
DIVISION OF INFORMATION SERVICES
112 STATE STREET, ROOM 500
ALBANY, NEW YORK 12207
PHONE: (518) 447-7277 FAX: (518) 447-3000
www.albanycounty.com

PERRY J. BLANCHARD
CHIEF INFORMATION OFFICER

TO: Karen Storm, Purchasing Agent
Division of Purchasing

FROM: Perry J. Blanchard
Chief Information Officer

DATE: May 2nd, 2022

RE: CAB Request

The Division of Information Services is putting in a CAB request with the vendor KnowBe4, for a not to exceed amount of \$29,317.32. Vendors were notified on the NYS Umbrella contract and we have not received any responses. If you have any questions, please contact 518-447-4843.

Thank you,
Perry Blanchard



DANIEL P. McCOY
COUNTY EXECUTIVE

COUNTY OF ALBANY
DEPARTMENT OF GENERAL SERVICES
PURCHASING DIVISION
112 STATE STREET, ROOM 1000
ALBANY, NEW YORK 12207-2021
(518) 447-7140 - FAX (518) 447-5588

DAVID M. LATINA
COMMISSIONER OF GENERAL SERVICES

PAMELA O NEILL
PURCHASING AGENT

MEMORANDUM

TO: Perry J. Blanchard
Chief Information Officer

FROM: Pamela O Neill *Pamela*
Purchasing Agent

DATE: May 2, 2022

RE: CAB Request

I am in receipt of your CAB recommendation to KnowBe4 in the amount of \$29,317.32.

As a quote was issued under the NYS Umbrella Contract and received no responses I concur with your recommendation to KnowBe4.

Please obtain the necessary contract approval of the Contract Administration Board so that we may issue a Notice of Award.



KnowBe4
33 N Garden Avenue, Suite 1200
Clearwater, FL
33755 US

Created Date 3/4/2022 2:31 PM
Expiration Date 5/29/2022
Quote Number Q-415958
Payment Terms Net 90

Prepared By Alex Lindner
Email alexl@knowbe4.com

Contact Name Perry Blanchard
Contact Phone 5184474962
Contact Email perry.blanchard@albanycountyny.gov

Bill to Name Albany County - NY
112 State St Rm 500
Albany, NY 12207-2023
USA

Ship To Name Albany County - NY
112 State St Rm 500
Albany, NY 12207-2023
USA

Description New Subscription Dates:
6/29/2022-6/28/2023

Notes

Total Term(Months) 12

Non Profit Discounting has been applied to this quote.

PRODUCT	DESCRIPTION	QTY	LIST PRICE	DISC. (%)	SALES PRICE	TOTAL PRICE
KMSATD	KnowBe4 Security Awareness Training Subscription Diamond	2,201	USD 16.65	20	USD 13.32	USD 29,317.32

Grand Total USD 29,317.32

Signature
Name
Title
Date

Terms & Conditions
Your signature on this quote tells us that you have the authority to make this purchase on behalf of your company and that you agree to pay within the stated terms. For first year subscriptions, mid-subscription add-ons, and/or upgrades, the subscription period will begin when we process your order, which is when we receive your signed quote. For renewal subscriptions, the subscription period will begin on the day after your current subscription expires. Unless included on the invoice, customer is responsible for any applicable sales and use tax. KnowBe4's standard Terms of Service (www.KnowBe4.com/Legal) and Product Privacy Policy (www.KnowBe4.com/Product-Privacy-Notice) apply, unless mutually agreed otherwise in writing.

Albany County Request for Contract Approval

Contract #	2022-325
Contract Type	B) CAB Contract
Contract Action	C) Renewal
Contract Action Type	C) Renewal
Department	A2960 - Service for Physically Handicapped Children
Date Submitted	Thursday, April 28, 2022
Contact Person	McNelis, Scott
Contact Phone	() -518
Vendor Info	See Attached NA, NA, NA NA
Estimated Amount	\$50,000.00
Estimated Term	7/1/2022 to 6/30/2023
Scope of Services	Mandated Related Services to meet the physical and educational needs of children ages 3 to 5 with disabilities. The Individualized Education Programs (IEP's) of many special education children prescribe instruction by Special Education Itinerant Teachers, as well as Related Services, such as Speech Pathology, Physical or Occupational therapies, to help the children attain their educational goals.
Budget Line Item	AA2960 - 44252 - - -
Fiscal Impact	County: 40.50% State: 59.50% Federal: 0.00% Local: 0.00% Other: 0.00%
BID, RFP, RFQ Completed?	N/A

Budget Analyst

Date

For Contract Board Use:

Date Approved

Daniel P. McCoy
Albany County Executive

Bruce A. Hidley
Albany County Clerk

Andrew Joyce, Chairman
Albany County Legislature



COUNTY OF ALBANY
DEPARTMENT FOR CHILDREN, YOUTH AND FAMILIES
DIVISION FOR CHILDREN WITH SPECIAL NEEDS
112 STATE STREET - SUITE 300
ALBANY, NEW YORK 12207
(518) 447-4820 - FAX (518) 447-5686

DANIEL P. MCCOY
COUNTY EXECUTIVE

DANIEL C. LYNCH
DEPUTY COUNTY EXECUTIVE

MOIRA E. MANNING
COMMISSIONER

NICOLE WARD
Deputy Commissioner

MEMORANDUM

TO: Hon. Daniel P. McCoy, County Executive
Hon. Andrew Joyce, Chairman of the Legislature
Hon. Bruce Hidley, County Clerk

FROM: Scott McNelis
Contract Administrator

RE: Contract Requests – Related Services Providers

DATE: May 9, 2022

The Albany County Department for Children, Youth and Families respectfully requests approval of the referenced contracts for Mandated Related Services to meet the physical and educational needs of children ages 3 to 5 with disabilities. The Individualized Education Programs (IEP's) of many special education children prescribe instruction by Special Education Itinerant Teachers, as well as Related Services, such as Speech Pathology, Physical or Occupational therapies, to help the children attain their educational goals.

Municipalities contract with private service providers. Rates are set by the State. The requested contract term is for July 1, 2022 – June 30, 2023.

Please call me at 447-7306 if you have any questions.

Enclosure

Albany County Department of Children Youth and Families
Justification and Backup Material for
Contractual Agreements between Albany County and Various Center Based
Providers for Preschool Children with Special Needs

The New York State Education Law (Section 4410) requires that the State Education Department meet the physical and educational needs of children with disabilities.

Under this law, municipalities are required to provide an approved preschool special education program for children age three to five who have been evaluated and determined by the Board of Education to have a disabling condition. Albany County contracts with service providers who have been approved by the Board of Education as having an appropriate, structured program capable of offering preschool education to children with disabilities. These providers deliver therapy as prescribed by individual education plans (IEPs) which are developed by school district based Committees on Preschool Special Education (CPSE).

The Department for Children, Youth and Families is requesting authorization to enter into a contractual agreement with those providers contained on the attached list for the term of July 1, 2022 – June 30, 2023. The Department is seeking authorization from the County Executive and the Contract Administration Board for those vendors with contractual amounts that fall within their request parameters.

The rates for these providers are set by New York State based on an entity's certified financial report. These interim rates are not available to either the vendor or the County until the early fall of a given year and may change an additional two times before being officially reconciled. The contract amounts for the 2022-2023 contract year assumes an increase of five (5) percent which will hopefully offset any rate increase or changes in utilization. However, in no instance will the County pay more than the State approved and authorized rate for a provider.

New York State reimburses Albany County 59.5% for costs incurred in the delivery of these services after backing out Medicaid reimbursement for the related services component (i.e. physical therapy, speech therapy, occupational therapy) of center based programs.

A child with special needs may be placed in an integrated class that contains children with and/or without other children with special needs. A Special Education Teacher and assistants are involved with the children throughout their educational program as well as a regular preschool or daycare teacher. A child may also be placed in a special class in which there are no more than twelve (12) children all of whom have special needs.

The Special Education teacher works directly with the child, the child's family and the child's regular teacher to help adapt an educational program to the child's needs. Some children in this model also receive related services therapies.

Albany County Request for Contract Approval

Contract #	2022-324
Contract Type	B) CAB Contract
Contract Action	C) Renewal
Contract Action Type	C) Renewal
Department	A2960 - Service for Physically Handicapped Children
Date Submitted	Thursday, April 28, 2022
Contact Person	McNelis, Scott
Contact Phone	() -518
Vendor Info	See Attached NA, NA, NA NA
Estimated Amount	\$90,000.00
Estimated Term	7/1/2022 to 6/30/2023
Scope of Services	Center Based Preschool Providers. The NYS Education Law (4410) requires Municipalities to provide an approved preschool special education program for children ages 3 to 5 who have been determined by the Board of Educ. to having a disabling condition. Albany County contracts with service providers who have been approved by the BOE as having an appropriate structured program capable of offering preschool education services to children with disabilities.
Budget Line Item	AA2960 - 44252 - - -
Fiscal Impact	County: 40.50% State: 59.50% Federal: 0.00% Local: 0.00% Other: 0.00%
BID, RFP, RFQ Completed?	N/A

Budget Analyst

Date

For Contract Board Use:

Date Approved

Daniel P. McCoy
Albany County Executive

Bruce A. Hidley
Albany County Clerk

Andrew Joyce, Chairman
Albany County Legislature



COUNTY OF ALBANY
DEPARTMENT FOR CHILDREN, YOUTH AND FAMILIES
DIVISION FOR CHILDREN WITH SPECIAL NEEDS
112 STATE STREET - SUITE 300
ALBANY, NEW YORK 12207
(518) 447-4820 - FAX (518) 447-5686

DANIEL P. MCCOY
COUNTY EXECUTIVE

DANIEL C. LYNCH
DEPUTY COUNTY EXECUTIVE

MOIRA E. MANNING
COMMISSIONER

NICOLE WARD
Deputy Commissioner

MEMORANDUM

TO: Hon. Daniel P. McCoy, County Executive
Hon. Andrew Joyce, Chairman of the Legislature
Hon. Bruce Hidley, County Clerk

FROM: Scott McNelis
Contract Administrator

RE: Contract Requests - Center Based Pre-School Providers

DATE: May 9, 2022

The Albany County Department for Children, Youth and Families respectfully requests approval of the referenced contracts for Center Based Pre-School Providers to provide an approved preschool special education program for children age 3 to 5 who have been determined by the Board of Ed to have a disabling condition. Albany County contracts with service providers who have been approved by the Board of Education as having an appropriate, structured program capable of offering preschool education to children with disabilities.

Municipalities contract with private service providers. Rates are set by the State. The requested contract term is for July 1, 2022 – June 30, 2023.

Please call me at 447-7306 if you have any questions.

Albany County Department of Children Youth and Families
Justification and Backup Material for Preschool
Related Services Program

The State Education Law requires the State Education Department (SED) to meet the physical and educational needs of children with disabilities.

The Individualized Education Programs (IEP's) of many special education children prescribe instruction by Special Education Itinerant Teachers, as well as Related Services, such as Speech Pathology, Physical or Occupational therapies, to name a few, to help them attain their educational goals.

Municipalities are mandated to contract with private service providers to obtain Related Services, in which the providers deliver in 30-60 minute sessions.

This option provides a child with the services of one or more therapists to meet his/her special needs. The therapist works with the child a specified number of times each week, and also interacts with the family and the staff of any typical program the child might attend. The therapy(ies) can be provided at any site, including the child's home, decided at the Committee on Preschool Special Education (CPSE) meeting.

The Albany County Department of Children Youth and Families Related Services Program provides a broad array of services to children ages 3 to 5, to meet the physical and educational needs of children with disabilities.

Attached is the list of contractors who require authorization.

Therefore, the Commissioner of the Department for Children, Youth and Families is requesting authorization for Albany County to enter into agreements with the attached listed providers for the term July 01, 2022 to June 30, 2023.

Related Service	Providers	CAB Requests	07/01/2022-	6/30/2023
PROVIDER	ADDRESS	DISCIPLINE	PAYMENTS 01/01/21 - 12/31/21	CONTRACT REQUEST 7/01/22 - 6/30/23
Cathryn Abbey	12 Darnley Greene Delmar, NY 12054	Speech Language Pathology	\$33,200.00	\$34,860.00
Access Therapy Group	515 Moe Road Clifton Park 12065	OT, PT, Psychology, Speech	\$39,050.00	\$41,002.50
Achievements	623 New London Road Latham, NY 12110	OT, PT, Psychology, Speech	\$83,053.00	\$87,205.65
Advanced Therapy PLLC	1 Rapp Road Albany NY 12203	OT, PT, Psychology, Speech	\$26,444.00	\$27,766.20
Marisa Bryant	53 Middlesex Drive Slingerlands, NY 12159	Speech Language Pathology	\$41,195.00	\$43,254.75
Camille Bushell	631 Salvia Lane Schenectady, NY 12303	Speech Language Pathology	\$65,945.00	\$69,242.25
Capital District Beginnings	597 Third Ave Troy, NY 12182	OT, PT, Psychology, Speech	\$28,239.00	\$29,650.95
Circle of Friends	14379 Route 9W Ravena, NY 12143	OT, PT, Psychology, Speech	\$79,871.00	\$83,864.55
Barbara Collins	208 Delaware Avenue Delmar NY 12054	Occupational Therapy	\$45,595.00	\$47,874.75
Sara Coons	419 Vischer Ferry Road, Clifton Park NY 12065	Speech Language Pathology	\$39,105.00	\$41,060.25
Early Childhood Education Center	230 Washington Ave Ext Albany, NY 12203	OT, PT, Psychology, Speech, Social Worker	\$48,015.00	\$50,415.75
Betty Gebauer	5005 Colonial Drive Schenectady NY 12303	Speech Language Pathology	\$19,305.00	\$20,270.25
Heidi Gray	28 Hancock Drive, Glenmont NY 12077	Occupational Therapy	\$24,750.00	\$25,987.50
Kristine Griffin	17 Outlook Drive South, Mechanicville NY 12118	Speech Language Pathology	\$43,890.00	\$46,084.50
Jill Hepp	23 West Sky Lane Clifton Park, NY 12065	Physical Therapy	\$19,140.00	\$20,097.00
Catherine Kunz	749 Sixth Avenue Troy NY 12182	Speech Language Pathology	\$44,110.00	\$46,315.50
Amy Leonard	26 Normanside Drive Albany, NY 12208	Occupational Therapy	\$26,840.00	\$28,182.00
Kathleen Megahey dba Reaching New Heights	53 Brookhaven Lane Glenmont NY 12077	Speech Language Pathology	\$43,615.00	\$45,795.75
Julie Murphy	29 Little Drive Ballston Spa NY 12020	Speech Language Pathology	\$33,550.00	\$35,227.50
Anna Patka	2 Glenwood Street Albany, NY 12203	Speech Language Pathology	\$42,735.00	\$44,871.75
Sarah Rosa	109 Pheasant Walk Schenectady NY 12303	Speech Language Pathology	\$52,415.00	\$55,035.75
Christine Roylance	11 Sandalwood Drive Loudonville, NY 12211	Occupational Therapy	\$35,915.00	\$37,710.75
Lori Hart-Ryan	108 Seneca Street Troy, NY 12180	Physical Therapy	\$33,990.00	\$35,689.50
Denise Senick - Pirri	14 Ridgefield Way Watervliet NY 12189	Speech Language Pathology	\$61,490.00	\$64,564.50
Carolyn Turner	232 Walnut Ln Slingerlands, NY 12159	Speech Language Pathology	\$70,235.00	\$73,746.75
A Child's Place @ Unity House	435 Fourth Street Troy NY 12180	OT, PT, Psych, Speech Language Pathology	\$37,928.00	\$39,824.40
Pauline K. Winkler Ctr @ College of Saint Rose	432 Western Ave Albany, NY 12203	Speech Language Pathology	\$27,403.00	\$28,773.15

Albany County Request for Contract Approval

Contract #	2022-264
Contract Type	B) CAB Contract
Contract Action	B) Amendment
Contract Action Type	B) Amendment
Department	A1620 - Building Services
Date Submitted	Wednesday, April 13, 2022
Contact Person	Stover, Thomas
Contact Phone	1 (518) 447-3020
Vendor Info	Rise Engineering 1341 Elmwood Ave, Cranston, RI 32910
Estimated Amount	\$10,000.00
Estimated Term	1/1/2022 to 6/30/2023
Scope of Services	Upon initial installation it was discovered and verified that the current fixtures at two of the facilities do not meet current safety codes. Rise Engineering will supply all materials and labor to ensure all newly installed fixtures are brought up to current codes, at an estimated cost of \$10,000.
Budget Line Item	AA1620 - 4046 - - -
Fiscal Impact	County: 100.00% State: 0.00% Federal: 0.00% Local: 0.00% Other: 0.00%
BID, RFP, RFQ Completed?	Yes - RFP

Budget Analyst

Date

For Contract Board Use:

Date Approved

Daniel P. McCoy
Albany County Executive

Bruce A. Hidley
Albany County Clerk

Andrew Joyce, Chairman
Albany County Legislature



DANIEL P. MCCOY
COUNTY EXECUTIVE

DANIEL C. LYNCH, ESQ.
DEPUTY COUNTY EXECUTIVE

COUNTY OF ALBANY
DEPARTMENT OF GENERAL SERVICES
112 STATE STREET, SUITE 825
ALBANY, NEW YORK 12207
(518) 447-7210 FAX (518) 447-7747
WWW.ALBANYCOUNTY.COM

DAVID M. LATINA
COMMISSIONER

SCOTT D. ALLARDICE
DEPUTY COMMISSIONER

April 11, 2022

Honorable Daniel P. McCoy
Albany County Executive
112 State Street, 12th Floor
Albany, New York 12207

Honorable Andrew Joyce, Chairman
Albany County Legislature
112 State Street, 7th Floor
Albany, New York 12207

Honorable Bruce A. Hidley
Albany County Clerk
Albany County Courthouse
15 Eagle Street, 1st Floor
Albany, New York 12207

Dear Messrs. McCoy, Joyce and Hidley:

The Department of General Services respectfully requests the approval of an additional \$10,000 for change orders to the contract with Rise Engineering for the upgrades of office lighting at the Board of Elections, Hall of Records and the Albany County Resource Center. Upon initial installation it was discovered and verified that the current fixtures at two of the facilities do not meet current safety codes. Rise Engineering will supply all materials and labor to ensure all newly installed fixtures are brought up to current codes, at an estimated cost of \$8,514.

The total estimated cost of this project was \$108,384.10. National Grid's SBC incentives total is \$36,551.75. With incentives this project had an estimated not to exceed cost of \$71,832.46. With the authorized additional funds, this project will now have a not to exceed total of \$81,832.46

The cost of the change orders will also be covered under bond number HKUV Res 503 of 2017 dated December 4, 2017.

If you have any questions regarding this matter, please do not hesitate to contact me.

Sincerely,

David M. Latina
Commissioner

DML:tas
Enclosure(s)

CHANGE ORDER



RISE
ENGINEERING

1341 Elmwood Avenue, Cranston, RI 02910

TO Albany County Resource Development Center	CHANGE ORDER NO.
ADDRESS 390 New Salem Rd	DATE 04/11/22
Voorheesville, NY 12186	PHONE
JOB NAME AND LOCATION	JOB NUMBER
	DATE OF EXISTING CONTRACT 11/3/21

- To independantly support luminaires (fixtures) from the ceiling grid. (238) qty
- Install new fixture whip feed to previously butted fixtures. (70) qty

Note: This revision becomes part of, and in conformance with, the existing contract.

WE AGREE hereby to make changes as specified above, at this price		\$ 4,697	00
Date _____	PREVIOUS CONTRACT AMOUNT	\$ 22,808	00
_____ (AUTHORIZED SIGNATURE)	REVISED CONTRACT TOTAL	\$ 27,505	00

ACCEPTED: The above prices and specifications of this Change Order are satisfactory and are hereby accepted. All work to be performed under same terms and conditions as specified in original contract unless otherwise stipulated.

DATE _____ SIGNATURE _____

CHANGE ORDER



RISE

ENGINEERING

1341 Elmwood Avenue, Cranston, RI 02910

TO Albany County Board of Elections	CHANGE ORDER NO.
ADDRESS 224 S. Pearl St	DATE 04/11/22
Albany, NY 12202	PHONE
JOB NAME AND LOCATION	JOB NUMBER
	DATE OF EXISTING CONTRACT 11/3/21

- To independantly support luminaires (fixtures) from the ceiling grid. (198) qty
- Install new fixture whip feed to previously butted fixtures. (20) qty

Note: This revision becomes part of, and in conformance with, the existing contract.

WE AGREE hereby to make changes as specified above, at this price		\$	3,817	00
Date _____	PREVIOUS CONTRACT AMOUNT	\$	23,832	00
_____ (AUTHORIZED SIGNATURE)	REVISED CONTRACT TOTAL	\$	27,649	00

ACCEPTED: The above prices and specifications of this Change Order are satisfactory and are hereby accepted. All work to be performed under same terms and conditions as specified in original contract unless otherwise stipulated.

DATE _____ SIGNATURE _____

AGREEMENT
BETWEEN THE COUNTY OF ALBANY
AND THIELSCH GROUP, INC.
FOR ENERGY EFFICIENT LIGHTING UPGRADES AT
THE BOARD OF ELECTIONS BUILDING, HALL OF RECORDS
AND ALBANY COUNTY RESOURCE CENTER

CONTRACT NO. 6666 FOR 2021

This is an Agreement made by and between the County of Albany, a municipal corporation, acting by and through its County Executive, within a principal place of business located at 112 State Street, Albany, New York 12207 (hereinafter, the "County" or "Owner") and Thielsch Group, Inc., a New York corporation, with a principal place of business located at 195 Frances Avenue, Cranston, Rhode Island 02910 (hereinafter, the "Contractor," and with the County, may be referred to herein individually as a "[p]arty" or together as the "[p]arties").

WITNESSETH

WHEREAS, by Resolution No. 411 of 2010, the Albany County Legislature adopted a comprehensive Energy and Environmental Sustainability Policy which established directives for the County to abide; and

WHEREAS, by Resolution No. 70 for 2014, the Albany County Legislature amended Resolution No. 411 of 2010 to provide for the purchase of efficient equipment and appliances, the improvement of lighting through the installation of new energy efficient bulbs countywide, the setting of thermostats for maximum energy conservation, and also the decrease in the plug load from office equipment; and

WHEREAS, in an effort to further the goals of the aforesaid Resolutions, the Commissioner of General Services has collaborated with the Consultant in connection with the National Grid Lighting Incentive Program and the County has entered into an agreement with the Consultant's Rise Engineering Division, the replacement and upgrade of lighting at the Board of Elections Building, the Hall of Records and the Albany County Resource Center (hereinafter, "Nat Grid Program Agreement"); and

WHEREAS, the Consultant has submitted a proposal dated November 3, 2021 for the aforesaid lighting replacement and upgrade (hereinafter, the "Proposal"); and

WHEREAS, the County has accepted the Consultant's Proposal; and

WHEREAS, this Agreement sets forth the understanding reached by the parties herein; and

NOW, THEREFORE THE PARTIES HERETO DO MUTUALLY COVENANT AND AGREE AS FOLLOWS:

ARTICLE 1. THE CONTRACT DOCUMENTS: INTERPRETATION

1.1 The Contract Documents consist of the following: this Agreement; the Nat Grid Program Agreement, incorporated by reference and made a part hereof; and the Proposal, attached hereto as Schedule A and made a part hereof (collectively, may be referred to herein as “the Agreement”).

1.2 In the event of any discrepancy, disagreement or ambiguity among the Contract Documents, the documents shall be given preference in the following order to interpret and to resolve such discrepancy, disagreement or ambiguity: 1) this Agreement; 2) the Nat Grid Program Agreement; 3) the Proposal.

ARTICLE 2. SCOPE OF SERVICES

2.1 The Consultant’s Rise Engineering Division shall perform the replacement and upgrading of lighting at the Board of Elections Building, the Hall of Records and the Albany County Resource Center in accordance with the Nat Grid Program Agreement.

2.2 In addition to the services described in Paragraph 2.2, above, the Consultant shall also provide the services described in the Proposal, in a manner consistent with the requirements, provisions, terms and conditions, etc. contained in the Nat Grid Program Agreement.

2.3 The Consultant shall not perform any services beyond those described in the Nat Grid Program Agreement or the Proposal (hereinafter, the “extra service(s)”) unless it has obtained prior written approval from the County.

2.4 The Consultant shall render all services in a professional manner.

ARTICLE 3. COMPENSATION

3.1 In consideration of the terms and obligations of this Agreement, the County agrees to pay, and the Consultant agrees to accept, an amount not to exceed SEVENTY ONE THOUSAND, EIGHT HUNDRED THIRTY THREE AND 00/100 DOLLARS (\$71,833.00) as full compensation for all services rendered under this Agreement.

3.2 The parties agree that the dollar amount identified in Paragraph 3.1 of this Agreement includes all expenses incurred providing the services and all travel costs, parking fees, overhead costs, profit and any other ancillary fees and costs including, but not limited to, permits, licenses and insurance.

ARTICLE 4. PAYMENT

Payment shall be made to the Consultant by the County on a monthly basis upon the Consultant’s submission of a properly executed Albany County Claim Form, plus all supporting documentation, to the Albany County Department of General Services. Upon review and approval of the claim form, payment shall be rendered promptly.

ARTICLE 5. TERM OF AGREEMENT

The term of this Agreement shall commence on January 1, 2022 and shall continue in effect through June 30, 2023.

ARTICLE 6. TERMINATION OF AGREEMENT; REMEDY FOR BREACH

6.1 This Agreement may be terminated by the County or the Consultant as follows:

6.1.1 The County may terminate the Agreement if the Consultant if the Consultant is substantially in breach of any of its provisions. Additionally, the County may, without cause, order the Consultant in writing, to suspend, delay or interrupt the services in whole or in part for such period of time as the County may determine.

6.1.2 The Consultant may terminate the Agreement if the County is substantially in breach of it.

6.2 In the event of a breach by the Consultant, the Consultant shall pay to the County all direct and consequential damages caused by such breach, including, but not limited to, all sums expended by the County to procure a substitute consultant to satisfactorily complete the services, together with the County's own costs incurred in procuring a substitute consultant.

ARTICLE 7. ASSIGNMENT

7.1 The Consultant specifically agrees as required by Section 109 of the N.Y. GENERAL MUNICIPAL LAW that the Consultant is prohibited from assigning, transferring, conveying, subcontracting or otherwise disposing of this Agreement, or of the Consultant's right, title, or interest therein, without the prior written consent of the County.

7.2 The Consultant shall not subcontract for any portion of the services required under this Agreement without the prior written approval of the County. Any such subcontractor shall be subject to the terms and conditions of this Agreement and any additional terms and conditions the County may deem necessary or appropriate.

ARTICLE 8. AVAILABLE DATA

All technical or other data relative to this Agreement in the possession of the County or in the possession of the Consultant shall be made available to the other party to this Agreement without expense to the other party.

ARTICLE 9. COOPERATION

The Consultant shall cooperate with representatives, agents and employees of the County and the County shall cooperate with representatives, agents and employees of the Consultant to the end that work may proceed expeditiously and economically.

ARTICLE 10. NON-DISCRIMINATION

In accordance with Article 15 of N.Y. EXECUTIVE LAW (also known as the Human Rights Law) and all other State and Federal statutory and constitutional non-discrimination provisions, the Consultant agrees that neither it nor any of its County approved sub-consultants shall, by reason of age, race, creed, color, national origin, sexual orientation, gender identity or expression, military status, sex, disability, predisposing genetic characteristics, familial status, marital status, or status as a victim of domestic violence, refuse to hire or employ or to bar or to discharge from employment such individual or to

discriminate against such individual in compensation or in terms, conditions or privileges of employment.

ARTICLE 11. RELATIONSHIP

The Consultant is, and shall function as, an independent consultant under the terms of this Agreement and shall not be considered an agent or employee of the County for any purpose. The employees and agents of the Consultant shall not in any manner be, or be held out to be, agents or employees of the County.

ARTICLE 12. INDEMNIFICATION

The Consultant shall defend, indemnify and save harmless the County, its employees and agents, from and against all claims, damages, losses and expenses (including, without limitation, reasonable attorney's fees) arising out of, or in consequence of, any negligent or intentional act or omission of the Consultant, its employees or agents, to the extent of its responsibility for such claims, damages, losses and expenses.

ARTICLE 13. NON-APPROPRIATIONS

Notwithstanding anything contained herein to the contrary, no default shall be deemed to occur in the event no funds or insufficient funds are appropriated and budgeted by or are otherwise unavailable to the County for payment under this Agreement. The County will immediately notify the Consultant of such occurrence and this Agreement shall terminate on the last day of the fiscal period for which appropriations were received without penalty or expense to the County of any kind whatsoever, except as to those portions herein agreed upon for which funds shall have been appropriated and budgeted.

ARTICLE 14. APPLICABLE LAW

The laws of the State of New York shall govern this Agreement. The designated venue is Albany, New York.

ARTICLE 15. RECORDS

Proper and full accounting records shall be maintained by the Consultant which records shall clearly identify the costs of the services/work performed. The records shall be subject to periodic and final audit by the County upon request. Such records shall be accessible to the County for a period of six (6) years following the date of final payment.

ARTICLE 16. INSURANCE

16.1 The Consultant shall procure and maintain for the entire term of this Agreement, without additional expense to the County, insurance policies of the kinds and in the amounts provided in the Schedule B attached hereto and made a part hereof. The insurance policies shall name the County as an additional insured. Such policies may only be changed upon 30 days prior written approval by the County.

16.2 The Consultant shall, prior to commencing any of the services outlined herein, furnish the County with Certificates of Insurance showing that the requirements of this article have been met. The Consultant shall also provide the County with updated Certificates of Insurance prior to the expiration of any previously-issued certificate. No work shall be commenced under this Agreement until the Consultant has delivered the Certificates of Insurance to the County. Upon failure of the Consultant to furnish, deliver and

maintain such insurance certificates as provided above, the County may declare this Agreement suspended, discontinued or terminated.

16.3 As required by Section 108 of the N.Y. GENERAL MUNICIPAL LAW, this Agreement shall be of no force and effect unless the Consultant shall secure compensation for the benefit of, and keep insured during the life of this Agreement, all employees engaged thereon in compliance with the provisions of the N.Y. WORKERS' COMPENSATION LAW. The Consultant shall require any subcontractor authorized by the County to do likewise for all of their employees engaged thereon, all in compliance with the provisions of the N.Y. WORKERS' COMPENSATION LAW and of Schedule B of this Agreement.

ARTICLE 17. NO WAIVER OF PERFORMANCE

Failure of the County to insist upon strict and prompt performance of the provisions of this Agreement, or any of them, and the acceptance of such performance thereafter shall not constitute or be construed as a waiver or relinquishment of the County's right thereafter to enforce the same strictly according to the tenor thereof in the event of a continuous or subsequent default on the part of the Consultant.

ARTICLE 18. MODIFICATION

This Agreement may only be modified by a formal written amendment executed by the parties.

ARTICLE 19. EXECUTION OF DOCUMENTS

This Agreement may be executed in one or more counterparts, each of which shall constitute an original Agreement, but all of which together shall constitute one and the same instrument.

ARTICLE 20. HEADINGS - CONSTRUCTION

The headings appearing in this Agreement are for the purpose of easy reference only and shall not be considered a part of this Agreement or in any way to modify, amend or affect the provisions hereof.

ARTICLE 21. ENTIRE AGREEMENT

This Agreement constitutes the entire Agreement between the parties and no representations or promises have been made except as herein expressly set forth.

ARTICLE 22. COMPLIANCE WITH MacBRIDE PRINCIPLES

The Consultant hereby represents that it is in compliance with the MacBride Principles of Fair Employment as set forth in Albany County Local Law No. 3 for 1993, in that the Consultant either (a) has no business operations in Northern Ireland or (b) shall take lawful steps in good faith to conduct any business operations in Northern Ireland in accordance with the MacBride Principles, and shall permit independent monitoring of its compliance with such principles. In the event of a violation of this stipulation, the County reserves all rights to take remedial measures as authorized under section 4 of Local Law No. 3 in 1993, including, but not limited to, imposing sanctions, seeking compliance, recovering damages, declaring the Consultant in default and/or seeking debarment or suspension of the Consultant.

ARTICLE 23. EXTRA SERVICES/WORK

If the Consultant is of the opinion that any services/work it has been directed to perform is beyond the scope of this Agreement and constitutes extra services/work, the Consultant shall promptly notify the County of that opinion. The County shall be the sole judge as to whether or not such services/work is in fact beyond the scope of this Agreement and whether or not it constitutes extra services/work. In the event the County determines such services/work does constitute extra services/work, it shall provide extra compensation to the Consultant on a negotiated basis.

ARTICLE 24. IRANIAN ENERGY SECTOR DIVESTMENT

The Consultant hereby represents that said consultant is in compliance with N.Y. GEN. MUN. LAW § 103-g entitled "Iranian Energy Sector Divestment," in that said consultant has not:

- a. Provided goods or services of \$20 Million or more in the energy sector of Iran including but not limited to the provision of oil or liquefied natural gas tankers or products used to construct or maintain pipelines used to transport oil or liquefied natural gas for the energy sector of Iran; or
- b. Acted as a financial institution and extended \$20 Million or more in credit to another person for 45 days or more, if that person's intent was to use the credit to provide goods or services in the energy sector in Iran.

ARTICLE 25. PREVAILING WAGE RATES AND SUPPLEMENTS

The Consultant shall at all times remain in compliance with Sections 220.3 and 220-d of the N.Y. LABOR LAW, which concern the payment of not less than the prevailing hourly wage rate for a legal day's work to each laborer, workman or mechanic employed by the Consultant in the provision of the services required under this Agreement. The Consultant shall submit payroll records to the County every thirty (30) days after issuance of its first payroll in accord with N.Y. LABOR LAW § 220 [3-a].

ARTICLE 26. MISCELLANEOUS PROVISIONS

26.1 In addition to the Iranian Energy Sector Divestment (per N.Y. GEN. MUN. LAW § 103-9) described above, the Consultant also acknowledges that it shall follow and all of the other policies and procedures described in the RFP.

26.2 During the term of this Agreement, the Consultant agrees that, in the event of its reorganization or dissolution as a business entity or change in business, the Consultant shall give the County 30 days written notice in advance of such event.

26.3 The Consultant shall at all times obtain and maintain all licenses and/or certifications required by New York State, or other relevant regulating body, to perform the services required under this Agreement.

26.4 If any term, part, provision, section, subdivision or paragraph of this Agreement shall be held to be unconstitutional, invalid or ineffective, in whole or in part, such determination shall not be deemed to invalidate the remaining terms, parts, provisions, sections, subdivisions or paragraphs.

26.5 The County shall bear no responsibility other than that set forth in this Agreement.

SCHEDULE A
SCOPE OF SERVICES

SEE ATTACHED PROPOSAL.

26.6 All notices, consents, waivers, directions, requests or other instruments or communications provided for under this Agreement shall be deemed properly given if, and only if, delivered personally, sent by registered or certified United States mail, postage prepaid, or, with the prior consent of the receiving party, dispatched via facsimile transmission.

IN WITNESS WHEREOF, the parties hereto have caused this Agreement to be signed the day and year first indicated below.

COUNTY OF ALBANY

DATED: 3/3/2022

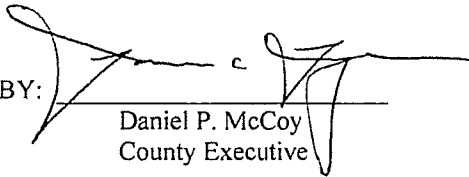
BY: 
Daniel P. McCoy
County Executive

or

Daniel C. Lynch
Deputy County Executive

THIELSCH GROUP, INC.

DATED: 2/22/22

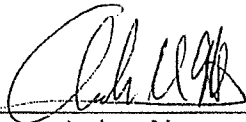
BY: 
Andrew Netto

Project Developer
Title

STATE OF NEW YORK)
COUNTY OF ALBANY) SS:

On the _____ day of _____, 2022, before me, the undersigned, personally appeared Daniel P. McCoy, personally known to me or proved to me on the basis of satisfactory evidence to be the individual whose name is subscribed to the within instrument and acknowledged to me that he executed the same in his capacity, and that by his signature on the instrument, the individual, or the person upon behalf of which the individual acted, executed the instrument.

Notary Public

STATE OF NEW YORK)
COUNTY OF ALBANY) SS.:

On the 3rd day of March, 2022, before me, the undersigned, personally appeared Daniel C. Lynch, personally known to me or proved to me on the basis of satisfactory evidence to be the individual whose name is subscribed to the within instrument and acknowledged to me that he executed the same in his capacity, and that by his signature on the instrument, the individual, or the person upon behalf of which the individual acted, executed the instrument.

Notary Public

EUGENIA K CONDON
Notary Public, State of New York
No. 02CO4969817
Qualified in Albany County
Commission Expires July 23, 2022

STATE OF NEW YORK)
COUNTY OF Saratoga) SS.:

On the 22nd day of February, 2022, before me, the undersigned, personally appeared Andrew Netto, personally known to me or proved to me on the basis of satisfactory evidence to be the individual whose name is subscribed to the within instrument and acknowledged to me that he executed the same in his capacity, and that by his signature on the instrument, the individual, or the person upon behalf of which the individual acted, executed the instrument.

Charlotte Seiz
Notary Public

CHARLOTTE A. SEVAZLIAN
NOTARY PUBLIC - STATE OF NEW YORK
Registration No. 01SE6187260
Qualified in Rensselaer County
My Commission Expires May 19, 20 24

SCHEDULE B
INSURANCE COVERAGE

The kinds and amounts of insurance to be provided are as follows:

1. Workers' Compensation and Employers Liability Insurance: A policy or policies providing protection for employees in the event of job related injuries or a waiver of the requirements of this insurance with such waiver to be issued by New York State.
2. Automobile Liability Insurance: A policy or policies with the limits of not less than \$500,000 for each accident because of bodily injury, sickness or disease, including death at any time, resulting therefrom, sustained by any person caused by accident, and arising out of the ownership, maintenance or use of any automobiles; and with the limits of \$500,000 for damage because of injury to or destruction of property, including the loss of the use thereof, caused by accident and arising out of the ownership, maintenance or use of any automobiles.
3. General Liability Insurance: A policy or policies of comprehensive all-risk insurance including coverage for demolition of structures with limits of not less than:

Liability For:	Combined Single Limit
Property Damage	\$1,000,000
Bodily Injury	\$1,000,000
Personal Injury	\$1,000,000.

4. Professional Liability Insurance: A policy or policies of professional liability insurance with limits of not less than \$1,000,000.

Albany County Request for Contract Approval

Contract #	2022-320
Contract Type	B) CAB Contract
Contract Action	B) Amendment
Contract Action Type	B) Amendment
Department	A1620 - Building Services
Date Submitted	Wednesday, April 27, 2022
Contact Person	Stover, Thomas
Contact Phone	1 (518) 447-3020
Vendor Info	AFSCO FENCE SUPPLY CO. 185 Troy-Schenectady Rd., LATHAM, NY 12110
Estimated Amount	\$2,000.00
Estimated Term	5/1/2022 to 10/31/2022
Scope of Services	To ensure complete enclosure of the area under the Spruce Street Garage an additional fifteen feet of fencing will need to be added to the project at a projected cost of \$2,000.00.
Budget Line Item	AA1620 - 4046 - - -
Fiscal Impact	County: 100.00% State: 0.00% Federal: 0.00% Local: 0.00% Other: 0.00%
BID, RFP, RFQ Completed?	Yes - RFQ

Budget Analyst

Date

For Contract Board Use:

Date Approved

Daniel P. McCoy
Albany County Executive

Bruce A. Hidley
Albany County Clerk

Andrew Joyce, Chairman
Albany County Legislature



DANIEL P. MCCOY
COUNTY EXECUTIVE

DANIEL C. LYNCH, ESQ.
DEPUTY COUNTY EXECUTIVE

COUNTY OF ALBANY
DEPARTMENT OF GENERAL SERVICES
112 STATE STREET, SUITE 825
ALBANY, NEW YORK 12207
(518) 447-7210 FAX (518) 447-7747
WWW.ALBANYCOUNTY.COM

DAVID M. LATINA
COMMISSIONER

SCOTT D. ALLARDICE
DEPUTY COMMISSIONER

April 27, 2022

Honorable Daniel P. McCoy
Albany County Executive
112 State Street, 12th Floor
Albany, New York 12207

Honorable Andrew Joyce, Chairman
Albany County Legislature
112 State Street, 7th Floor
Albany, New York 12207

Honorable Bruce A. Hidley
Albany County Clerk
Albany County Courthouse
15 Eagle Street, 1st Floor
Albany, New York 12207

Dear Messrs. McCoy, Joyce and Hidley:

The Department of General Services respectfully requests the approval of an additional \$2,000 for a change order to the contract with AFSCO Fence Supply Co.

To ensure complete enclosure of the area under the Spruce Street Garage an additional fifteen feet of fencing will need to be added to the project at a projected cost of \$1,460.00. An additional \$540.00 contingency allowance is being included for any additional unforeseen issues. The original contract is 2022-255 for \$22,100.

If you have any questions regarding this matter, please do not hesitate to contact me.

Sincerely,

David M. Latina
Commissioner

DML:tas
Enclosure(s)



AFSCO FENCE SUPPLY CO., INC.

185 Troy-Schenectady Rd.
PO Box 98
Latham, NY 12110-0098
(518) 783-0395; fax (518) 783-9333

34 Big Boom Rd.
Queensbury, NY 12804
(518) 792-7076; fax (518) 798-5836

April 27th, 2022

We propose, subject to acceptance, to sell and/or install the materials enumerated below:
Title to materials remains with AFSCO Fence until paid in full.

Name: ALBANY COUNTY DGS
112 STATE STREET
ALBANY, NY 12207
ATTN: SCOTT ALLARDICE

Ship To: OVERPASS
3 SPRUCE STREET
ALBANY, NY

This contract is subject to terms, covenants, and conditions on part II of Proposal
PROPOSAL (Part I of II)

****PRICES GOOD FOR 15 DAYS FROM DATE OF QUOTE****

EXTRA FENCE

Furnish an additional 13 +/- lineal feet of new, 8' high, 9 gauge, galvanized, chain link fencing on galvanized, industrial grade (SS-40 weight), fencing framework. New fence to have a continuous top rail and bottom rail. AFSCO will drive posts to grade (30" depth) if possible or core drill and grout posts in place (if rock & concrete conditions prevent post driving).

MATERIALS, LABOR & EQUIPMENT \$1,460.00

IF REQUIRED

- **BUILDING PERMITS BY OTHERS.**
- **LINES TO BE CLEAR & STAKED BY OTHERS.**
- **PROPER TAX EXEMPT CERTIFICATE NEEDED WITH ORDER.**
- **ALL PRIVATE UNDERGROUND UTILITIES TO BE STAKED BY OWNER.**

RECOMMENDED BY: _____
Owner/Operator **BRUCE A. SCHROEDER**

ACCEPTED BY: _____ this _____ day of _____ 20 _____
Purchaser

AGREEMENT
BETWEEN THE COUNTY OF ALBANY
AND AFSCO FENCE SUPPLY CO., INC.

Contract No. 2022-255

This Agreement is made by and between the County of Albany, a municipal corporation organized under the laws of the State of New York, acting by and through its County Executive, with a principal office at 112 State Street, Albany, New York 12207 (hereinafter referred to as the "County"), and Afsco Fence Supply Co., a corporation with a principal office at 185 Troy- Schenectady Road, Latham, New York 12110 (hereinafter referred to as the "Contractor," the County and the Contractor may be referred to as the "Party" or "Parties" as appropriate).

WITNESSETH:

WHEREAS, the County has a need for a vendor to furnish and install new chain link fencing; and

WHEREAS, the contractor has submitted a quote to provide the aforesaid services to the County; and

WHEREAS, the County has accepted the Quote from the Contractor to provide the aforesaid services from the Contractor; and

WHEREAS, in furtherance thereof, the parties hereto desire to formalize their understanding and agreement regarding the provision of the aforementioned services, and to execute a fully-integrated agreement with respect thereto;

NOW, THEREFORE, THE PARTIES HERETO DO MUTUALLY COVENANT AND AGREE AS FOLLOWS:

ARTICLE I. THE CONTRACT DOCUMENTS; INTERPRETATION

1.1 The Contract Documents consist of the following: this Agreement; and the Contractor's Quote, which is incorporated by reference and made a part hereof (collectively referred to as "the Agreement").

1.2 In the event of any discrepancy, disagreement or ambiguity among the Contract Documents, the documents shall be given preference in the following order to interpret and to resolve such discrepancy, disagreement or ambiguity: 1) this Agreement; 2) the Contractor's quote.

ARTICLE II. SCOPE OF SERVICES TO BE PERFORMED BY CONTRACTOR

Contractor shall furnish and install new chain link fencing. These services are more particularized in the Contractor's Quote, attached hereto as Schedule B.

ARTICLE III. COMPENSATION

In consideration of the terms and obligations of this Agreement, the County agrees to pay and the Contractor agrees to accept an amount not to exceed TWENTY-TWO THOUSAND, ONE HUNDRED AND 00/100 (\$22,100.00) DOLLARS (US CURRENCY).

ARTICLE IV. PAYMENT

Payment shall be made to the Contractor on monthly basis upon the Contractor's submission of a properly executed Albany County Claim Form, plus all supporting documentation, to the County, and acceptance by the County of the claim form.

ARTICLE V. TERM OF THE AGREEMENT

The term of this Agreement shall commence upon May 1, 2022 and shall continue until October 31, 2022.

ARTICLE VI. TERMINATION OF AGREEMENT; REMEDY FOR BREACH

6.1 This Agreement may be terminated by the County or the Contractor as follows:

6.1.1 The County may terminate this Agreement if the Contractor refuses or fails to supply enough properly skilled workers or proper materials to meet any of its

requirements, if the Contractor fails to make payment to County-approved subcontractors for materials or labor, or disregards laws, ordinances or rules and regulations or orders of a public entity having jurisdiction over the work, or if the Contractor is substantially in breach of any of its provisions. Additionally, the County may, without cause, order the Contractor in writing, to suspend, delay or interrupt the work in whole or in part for such period of time as the County may determine.

6.1.2 The Contractor may terminate this Agreement if the County is substantially in breach of it.

6.2 In the event of a breach by the Contractor, the Contractor shall pay to the County all direct and consequential damages caused by such breach, including, but not limited to, all sums expended by the County to procure a substitute Contractor to satisfactorily complete the work, together with the County's own costs incurred in procuring a substitute Contractor.

ARTICLE VII. PROHIBITION OF CONTRACT ASSIGNMENT

7.1 Pursuant to §109 of the General Municipal Law, the Contractor is prohibited from assigning, transferring, conveying, subcontracting or otherwise disposing of this Agreement, or of its right, title or interest therein, to any other person or entity without the prior written consent of the County.

7.2 The Contractor shall not subcontract for any portion of the services required under this Agreement without the prior written approval of the County. Any such subcontractor shall be subject to the terms and conditions of this Agreement and any additional terms and conditions the County may deem necessary or appropriate.

ARTICLE VIII. AVAILABLE DATA

All technical or other data relative to this Agreement in the possession of the County or in the possession of the Contractor shall be made available to the other party to this Agreement without expense to the other party.

ARTICLE IX. COOPERATION

Contractor shall cooperate with the agents, representatives, and employees of the County and the County shall cooperate with the agents, representatives and employees of the Contractor to ensure that the work delineated herein proceeds and concludes as expeditiously as possible.

ARTICLE X. PREVAILING WAGE

The Contractor shall at all times remain in compliance with Sections 220.3 and 220-d of the N.Y. Labor Law, which concern the payment of not less than the prevailing hourly wage rate for a legal day's work to each laborer, workman or mechanic employed by the Contractor in the provision of the services required under this Agreement. The Contractor shall submit payroll records to the County every thirty (30) days after issuance of its first payroll in accord with N.Y. Labor Law Section 220 [3-a]a.

ARTICLE XI. NON-DISCRIMINATION

In accordance with Article 15 of the Executive Law (also known as the Human Rights Law), and all other State and Federal statutory and constitutional non-discrimination provisions, the Contractor agrees that neither it nor its County-approved subcontractors shall, by reason of age, race, creed, color, national origin, sexual orientation, military status, sex, disability, predisposing genetic characteristics, or marital status refuse to hire or employ or to bar or to discharge from employment such individual or to discriminate against such individual in compensation or in terms, conditions or privileges of employment.

ARTICLE XII. COMPLIANCE WITH MACBRIDE PRINCIPLES

Contractor hereby represents that it is in compliance with the MacBride Principles of Fair Employment as set forth in Albany County Local Law No. 3 for 1993, in that Contractor either (a) has no business operations in Northern Ireland or (b) shall take lawful steps in good faith to conduct any business operations in Northern Ireland in accordance with the MacBride Principles, and shall permit independent monitoring of its compliance with such principles. In the event of a violation of this stipulation, the County reserves all rights to take remedial measures as authorized under § 4 of the said Local Law No. 3 for 1993 including, but not limited to, imposing sanctions, enforcing compliance, recovering damages,

declaring the Contractor in default, and/or seeking debarment or suspension of the Contractor.

ARTICLE XIII. IRANIAN ENERGY SECTOR DIVESTMENT

Contractor hereby represents that Contractor is in compliance with New York State General Municipal Law Section 103-g entitled "Iranian Energy Sector Divestment," in that Contractor has not:

- (a) Provided goods or services of \$20 Million or more in the energy sector of Iran including but not limited to the provision of oil or liquefied natural gas tankers or products used to construct or maintain pipelines used to transport oil or liquefied natural gas for the energy sector of Iran; or
- (b) Acted as a financial institution and extended \$20 Million or more in credit to another person for forty-five days or more, if that person's intent was to use the credit to provide goods or services in the energy sector in Iran.

ARTICLE XIV. RELATIONSHIP OF THE PARTIES

Contractor is, and will function as, an independent Contractor under the terms of this Agreement, and shall not be considered an agent or employee of the County for any purpose. The agents, representatives and employees of the Contractor shall not in any manner be, or be held out to be, the agents, representatives or employees of the County.

ARTICLE XV. INDEMNIFICATION

Contractor shall defend, indemnify and save harmless the County, its agents representatives, and employees, from and against any and all claims, damages, losses and expenses (including, but not limited to, reasonable attorney's fees) arising out of or in consequence of any negligent or intentional act or omission of the Contractor, its agents or employees, to the extent of its or their responsibility for such claims, damages, losses or expenses.

ARTICLE XVI. INSURANCE COVERAGE

- 16.1 Contractor shall procure and maintain for the entire term of this Agreement, without additional expense to the County, insurance policies of the kinds and in the amounts provided in the Schedule "A" attached hereto and made a part hereof. The insurance policies shall name the County as an additional insured. Such policies may only be changed upon thirty (30) days prior written approval by the County.
- 16.2 Contractor shall, prior to commencing any of the services outlined herein, furnish the County with Certificates of Insurance showing that the requirements of this article have been met. The Contractor shall also provide the County with updated Certificates of Insurance prior to the expiration of any previously-issued Contractor. No work shall be commenced under this Agreement until the Contractor has delivered the Certificates of Insurance to the County. Upon failure of the Contractor to furnish, deliver and maintain such insurance certificates as provided above, the County may declare this Agreement suspended, discontinued or terminated.
- 16.3 As required by Section 108 of the N.Y. General Municipal Law, this Agreement shall be of no force and effect unless the Contractor shall secure compensation for the benefit of, and keep insured during the life of this Agreement, all employees engaged thereon in compliance with the provisions of the N.Y. Workers' Compensation Law. The Contractor shall require any subcontractor authorized by the County to do likewise for all of their employees engaged thereon, all in compliance with the provisions of the N.Y. Workers' Compensation Law and of Schedule "A" of this Agreement.

ARTICLE XVII. NON-COLLUSIVE BIDDING

By execution of this Agreement, Contractor warrants, under penalty of perjury, that to the best of knowledge and belief; the prices communicated to the County in establishing the costs of goods and services covered in this Agreement have been arrived at independently without collusion, consultation, communication or agreement for the purpose of restricting competition. Contractor warrants that it is in compliance with NYS General Municipal Law Sec. 103-d with regard to the prices of goods and services covered in this Agreement.

ARTICLE XVIII. NO WAIVER OF PERFORMANCE

Failure of the County to insist upon strict and prompt performance of the provisions of this Agreement, or any of them, and the acceptance of such performance thereafter shall not constitute or be construed as a waiver or relinquishment of the County's right thereafter to enforce the same strictly according to the tenor thereof in the event of a continuous or subsequent default on the part of the Contractor.

ARTICLE XIX. ACCOUNTING RECORDS

- 19.1 Contractor shall maintain complete and proper accounting records that shall clearly identify all costs associated with and revenue derived from the work performed under this Agreement. Such records shall be subject to periodic and final audit by the County upon request.
- 19.2 Contractor shall provide the County and authorized State and/or Federal personnel access to any and all books, documents, records, charts, software or any other information relevant to performance under this Agreement, immediately upon request.
- 19.3 Contractor shall retain all of the above information for six (6) years after final payment or the termination of this Agreement, and shall make such information available to the County and authorized State and/or Federal personnel during such period.

ARTICLE XX. NON-APPROPRIATIONS

Notwithstanding anything contained herein to the contrary, no default shall be deemed to occur in the event no funds or insufficient funds are appropriated and budgeted by or are otherwise unavailable to the County for payment under this Agreement. The County will immediately notify the Contractor of such occurrence and this Agreement shall terminate on the last day of the fiscal period for which appropriations were received without penalty or expense to the County of any kind whatsoever, except as to those portions herein agreed upon for which funds shall have been appropriated and budgeted.

ARTICLE XXI. NON-INTERRUPTION OF WORK

The Contractor agrees that it will not intentionally engage in any course of conduct or activity, or employ for the purposes of performing the public work, any subcontractors, employees, labor or materials which will or may result in the interruption of the performance of the public work due to labor strife or unrest by workmen employed by the Contractor or by any of the trades working in or about the public works and/or premises where the work is being performed.

ARTICLE XXII. EXTRA WORK

If the Contractor is of the opinion that any work it has been directed to perform is beyond the scope of this Agreement and constitutes extra work, the Contractor shall promptly notify the County of that opinion. The County shall be the sole judge as to whether or not such work is in fact beyond the scope of this Agreement and whether or not it constitutes extra work. In the event the County determines such work does constitute extra work, it shall provide extra compensation to the Contractor on a negotiated basis.

ARTICLE XXIII. CHANGE IN LEGAL STATUS OR DISSOLUTION

During the term of this Agreement, the Contractor agrees that, in the event of its reorganization or dissolution as a business entity or change in business, the Contractor shall give the County thirty (30) days written notice in advance of such event.

ARTICLE XXIV. LICENSES

The Contractor shall at all times obtain and maintain all licenses required by New York State, or other relevant regulating body, to perform the services required under this Agreement.

ARTICLE XXV. PARTIAL INVALIDITY

If any term, part, provision, section, subdivision or paragraph of this Agreement shall be held to be unconstitutional, invalid or ineffective, in whole or in part, such determination shall not be deemed to invalidate the remaining terms, parts, provisions, sections, subdivisions or paragraphs.

ARTICLE XXVI. HEADINGS – CONSTRUCTION

The headings appearing in this Agreement are for the purpose of easy reference only and shall not be considered a part of the Agreement or in any way to modify, amend or affect the provisions hereof.

ARTICLE XXVII. NOTICES

All notices, consents, waivers, directions, requests or other instruments or communications provided for under this Agreement shall be deemed properly given if, and only if, delivered personally, sent by registered or certified United States mail, postage prepaid, or, with the prior consent of the receiving party, dispatched via facsimile transmission.

ARTICLE XXVIII. GOVERNING LAW

This Agreement shall be governed by and construed in accordance with the laws of the State of New York.

ARTICLE XXIX. ENTIRE AGREEMENT

This Agreement constitutes the entire agreement between the parties and no representations or promises have been made except as expressly set forth herein.

ARTICLE XXX. MODIFICATION

This Agreement may only be modified by a formal written amendment executed by the parties.

ARTICLE XXXI. EXECUTION OF DOCUMENTS

This Agreement may be executed in one or more counterparts, each of which shall constitute an original Agreement, but all of which together shall constitute one and the same instrument.

IN WITNESS WHEREOF, the parties hereto have executed this Agreement on the date(s) hereunder set forth.

COUNTY OF ALBANY

DATED: 4/19/2022

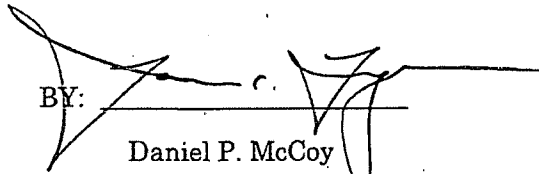
BY: 

Daniel P. McCoy
Albany County Executive

or

Daniel C. Lynch
Deputy County Executive

AFSCO FENCE SUPPLY CO., INC.

DATED: 4/13/2022

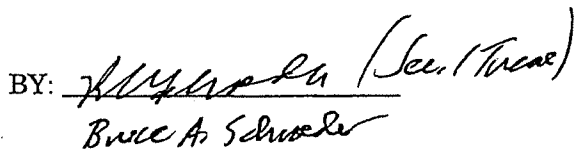
BY:  (Sec. Treas.)
Bruce A. Schwab

STATE OF NEW YORK)
COUNTY OF ALBANY) SS:

On the _____ day of _____, 2022, before me, the undersigned, personally appeared Daniel P. McCoy, personally known to me or proved to me on the basis of satisfactory evidence to be the individual whose name is subscribed to the within instrument and acknowledged to me that he executed the same in his capacity, and that by his signature on the instrument, the individual, or the person upon behalf of which the individual acted, executed the instrument.

Notary Public

STATE OF NEW YORK)
COUNTY OF ALBANY) SS.:

On the 19th day of April, 2022, before me, the undersigned, personally appeared Daniel C. Lynch, personally known to me or proved to me on the basis of satisfactory evidence to be the individual whose name is subscribed to the within instrument and acknowledged to me that he executed the same in his capacity, and that by his signature on the instrument, the individual, or the person upon behalf of which the individual acted, executed the instrument.

Notary Public

EUGENIA K. CONDON
Notary Public State of New York
No. 02CO4969817
Qualified in Albany County
Commission Expires July 23, 2022

STATE OF NEW YORK)
COUNTY OF Albany) SS.:

On the 13th day of April, 2022, before me, the undersigned, personally appeared Bruce A. Schroeder, personally known to me or proved to me on the basis of satisfactory evidence to be the individual whose name is subscribed to the within instrument and acknowledged to me that he/she/they executed the same in his/her/their capacity, and that by his/her/their signature on the instrument, the individual, or the person upon behalf of which the individual acted, executed the instrument.

RICHARD M MARCIANO
Notary Public, State of New York
No. 01MA5057283
Qualified in Saratoga County
Commission Expires May 10, 2022

Notary Public

SCHEDULE "A"
INSURANCE COVERAGE

1. **Workers' Compensation and Employers' Liability Insurance:** A policy or policies providing protection for employees in the event of job-related injuries.

2. **Automobile Liability Insurance:** A policy or policies with the limits of not less than \$500,000 combined for each accident because of bodily injury, sickness, or disease, sustained by any person, caused by accident, and arising out of the ownership, maintenance or use of any automobile for damage because of injury to or destruction of property, including the loss of use thereof, caused by accident and arising out of the ownership, maintenance, or use of any automobile.

3. **General Liability Insurance:** A policy or policies of comprehensive all-risk insurance, including coverage for demolition of structures, with limits of not less than:

Liability For:	Combined Single Limit
Property Damage	\$1,000,000
Bodily Injury	\$1,000,000
Personal Injury	\$1,000,000

SCHEDULE "B"
Contractor's Quote



AFSCO FENCE SUPPLY CO., INC.

185 Troy-Schenectady Rd.
PO Box 98
Latham, NY 12110-0098
(518) 783-0395; fax (518) 783-9333

34 Big Boom Rd.
Queensbury, NY 12804
(518) 792-7076; fax (518) 798-5836

March 29th, 2022

We propose, subject to acceptance, to sell and/or install the materials enumerated below:
Title to materials remains with AFSCO Fence until paid in full.

Name: ALBANY COUNTY DGS
112 STATE STREET
ALBANY, NY 12207
ATTN: SCOTT ALLARDICE

Ship To: OVERPASS
3 SPRUCE STREET
ALBANY, NY

This contract is subject to terms, covenants, and conditions on part II of Proposal
PROPOSAL (Part I of II)

****PRICES GOOD FOR 15 DAYS FROM DATE OF QUOTE****

8' CHAIN LINK FENCE

Furnish and install 185 +/- lineal feet of new, 8' high, 9 gauge, galvanized, chain link fencing on galvanized, industrial grade (SS-40 weight), fencing framework. Included is one (1) each 4' wide single gate with standard industrial grade hardware (hinges & latch). Lock for gate by others. New fence to have a continuous top rail and bottom rail. AFSCO will drive posts to grade (30" depth) if possible or core drill and grout posts in place (if rock & concrete conditions prevent post driving).

MATERIALS, LABOR & EQUIPMENT \$22,100.00

IF REQUIRED

- BUILDING PERMITS BY OTHERS.
- LINES TO BE CLEAR & STAKED BY OTHERS.
- PROPER TAX EXEMPT CERTIFICATE NEEDED WITH ORDER.
- ALL PRIVATE UNDERGROUND UTILITIES TO BE STAKED BY OWNER.

RECOMMENDED BY:

Owner/Operator

BRUCE A. SCHROEDER

ACCEPTED BY:

_____ this _____ day of _____ 20 _____

Purchaser